

HygroPalm AW1
Portable Water Activity Indicator
Instruction Manual
v 3



Contents

Overview.....	3
General Description.....	4
Power Requirements.....	4
Optional Docking Station (PalmDock).....	4
Display.....	6
Keypad.....	7
Temperature Unit.....	7
Operation.....	7
Operating Modes.....	8
Mode Selection.....	8
Water Activity Measurement.....	11
Water Activity: definition and applications.....	11
General Recommendations.....	13
Using the AwQuick Mode.....	15
Using the AwE Mode.....	17
Function Menu.....	18
MODE.....	18
ADJUST M.PT (full probe calibration against a reference).....	19
ADJUST 1PT (1-point adjustment against a reference).....	20
SETTINGS.....	22
PROBE.....	22
SYS STATUS.....	23
Errors and Status Messages.....	23
Environmental Limits.....	24
Maintenance.....	24
Specifications.....	24
Appendix 1: Practical Advice for Measuring Aw.....	25
Appendix 2: Maintenance of the ROTRONIC probes.....	27
Cleaning or Replacing the Dust Filter of the Probe.....	27
Periodic Calibration Check of the Probes.....	27
Appendix 3: Calibration Basics.....	28
Temperature Calibration.....	28
Humidity Calibration.....	28
Appendix 4: Accessories and spare parts.....	30

Note: functions such as instrument configuration with a PC as well as the calibration of HygroClip probes separately from the HygroPalm AW1 require the optional HW3 PC software. Instructions for using the HW3 software are not included in this manual. These instructions are shipped separately on the same CD ROM as the HW3 software.

About the version number: this manual is valid for all instruments with version number 3.x, where 3.x can be 3.0, 3.1, etc. (see MENU, SYS STATUS). Changes in the last digit of the version number reflect minor changes in the internal software of the instrument that do not affect the manner in which the instrument should be operated.

Overview

The HygroPalm AW1 is a portable water activity and temperature indicator that is available with probes of different configuration for measuring product samples, materials in bulk such as powders, seeds, etc., packaging materials, etc.

In addition to the basic function of indicating water activity and temperature (standard operating mode), the HygroPalm AW1 features two operating modes that are especially useful when measuring water activity:

AwQuick mode: permits measuring the water activity of most products in typically 5 minutes. The measurement is ended automatically.

AwE mode: same as the standard operating mode with the difference that the HygroPalm AW1 automatically detects equilibrium conditions and ends the measurement at that time.

The HygroPalm AW1 operates with a regular 9V alkaline battery or with a rechargeable 9V battery. The optional docking station makes it possible to use the HygroPalm AW1 as a table top indicator and to power it with an AC adapter.

Main features:

- indication of water activity and temperature
- AwQuick mode: accelerated water activity measurement (typically 5 minutes)
- AwE mode: conventional water activity measurement
- automatic indication of measurement end
- single probe input, compatible with any ROTRONIC HygroClip digital probe
- software-based probe calibration (1-point or multi-point) directly from keypad
- temperature unit ($^{\circ}\text{C}$ or $^{\circ}\text{F}$) selectable from keypad

HygroPalm AW1

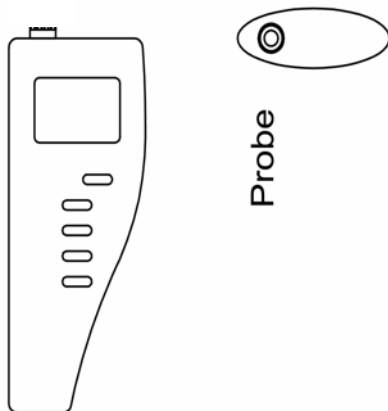

Docking Station (PalmDock)

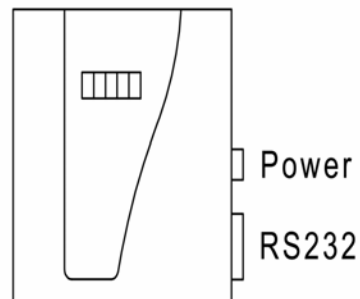

General Description

Power Requirements

The HygroPalm AW1 operates with a regular 9V alkaline battery or with a 9V rechargeable battery.

Important: the HygroPalm AW1 is shipped with a regular 9V battery and is factory preset with the battery charge function turned off. If you plan on using a rechargeable battery (requires docking station), you should turn on the battery charge function (see Function Menu – Settings). Before using a regular battery again, be sure to turn off the battery charge function. Trying to charge a regular battery may cause the battery to burst and may damage the instrument.

Optional Docking Station (PalmDock)

The HygroPalm AW1 is available with an optional docking station. The docking station accepts an external AC adapter. When the HygroPalm AW1 is equipped with a rechargeable battery, the docking station can be used to recharge the battery (after turning on the battery charge function – see settings). The RS232 port of the docking station is not used with the HygroPalm AW1 (this port is used with other models of HygroPalm).

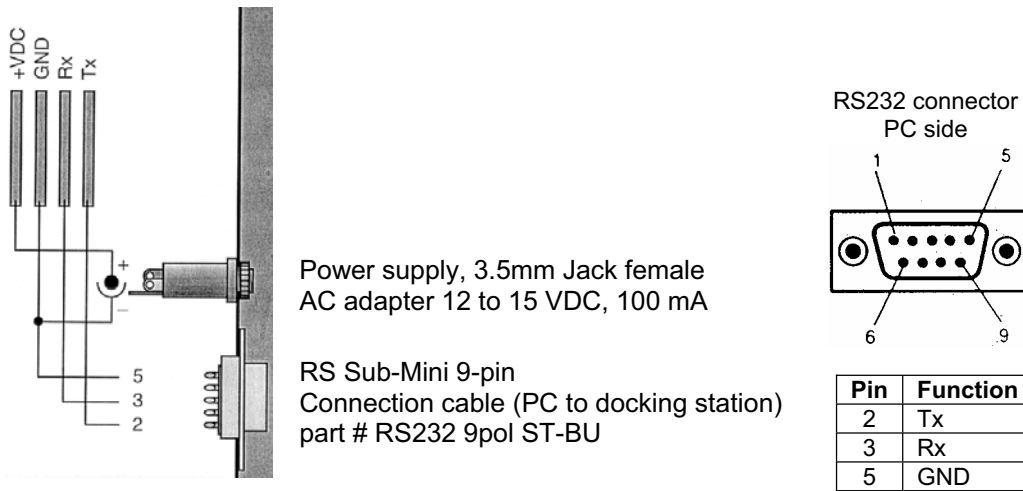

HygroClip Digital Probes

The ROTRONIC HygroClip digital humidity temperature probes permit to take full advantage of all the features and functions of the HygroPalm AW1. These probes are highly accurate and are calibrated entirely by means of software (no adjustment potentiometers). Because calibration and other data are stored in the probe non-volatile memory, the probes are fully interchangeable. When a probe requires calibration or has to be repaired, it can be replaced with another probe in a few seconds.

The ROTRONIC HygroClip digital probes are available in different configurations so as to permit different types of water activity measurement:

Small product samples: AW-DIO and AwVC-DIO probe

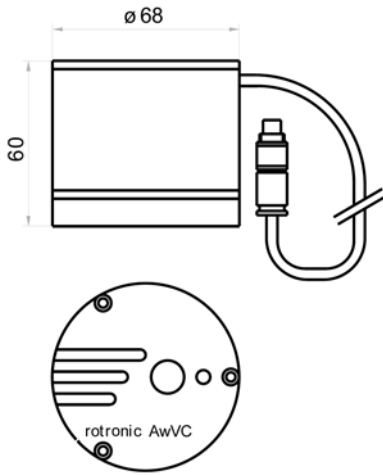

Both probes are physically the same with the difference that the AwVC-DIO incorporates a small fan to ventilate the product sample. This can be beneficial when measuring chunky product samples.

Both probes have a B5 connector and can be directly connected to the HygroPalm AW1.

The AW-DIO and AwVC-DIO probes require the use of a sample holder. Sample holders are available in two sizes: 14 and 40 mm deep. Disposable sample cups are used to collect samples and to prevent contamination between samples.

Note: all of the following probes have a DAT-05 connector and require an adapter cable MOK-01-B5 for connection to the HygroPalm AW1 (see Appendix 4: Accessories).

Materials in bulk: HP28 insertion probe

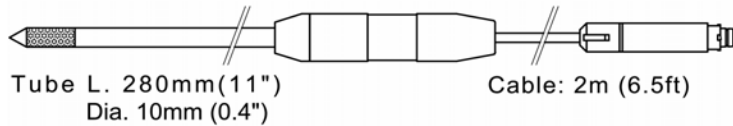

This probe is used to measure seeds, barrels of pharmaceutical powders, etc.

Shipping containers and other tight spaces: SC05 miniature probe

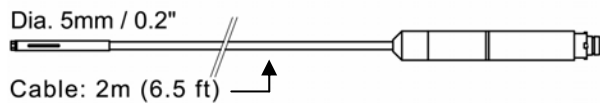

Packaging materials (stacks/rolls of paper and cardboard): HS28 Sword probe



Blade L. 280mm(11")
W. 18mm(0.7")
T. 4mm(0.16")

Cable: 2m (6.5ft)

Display

The LC display shows the water activity and temperature by the probe, with the associated engineering unit. When relevant, the message line provides additional information.

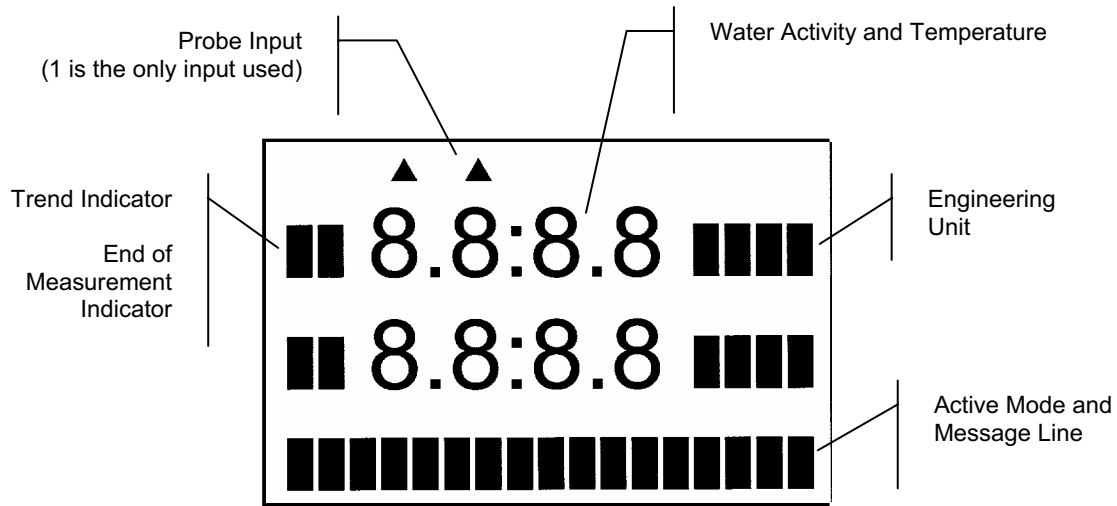

The display provides information regarding the battery status. When the message Low Batt appears, the instrument can typically be used for another 10 to 15 minutes.

Keypad

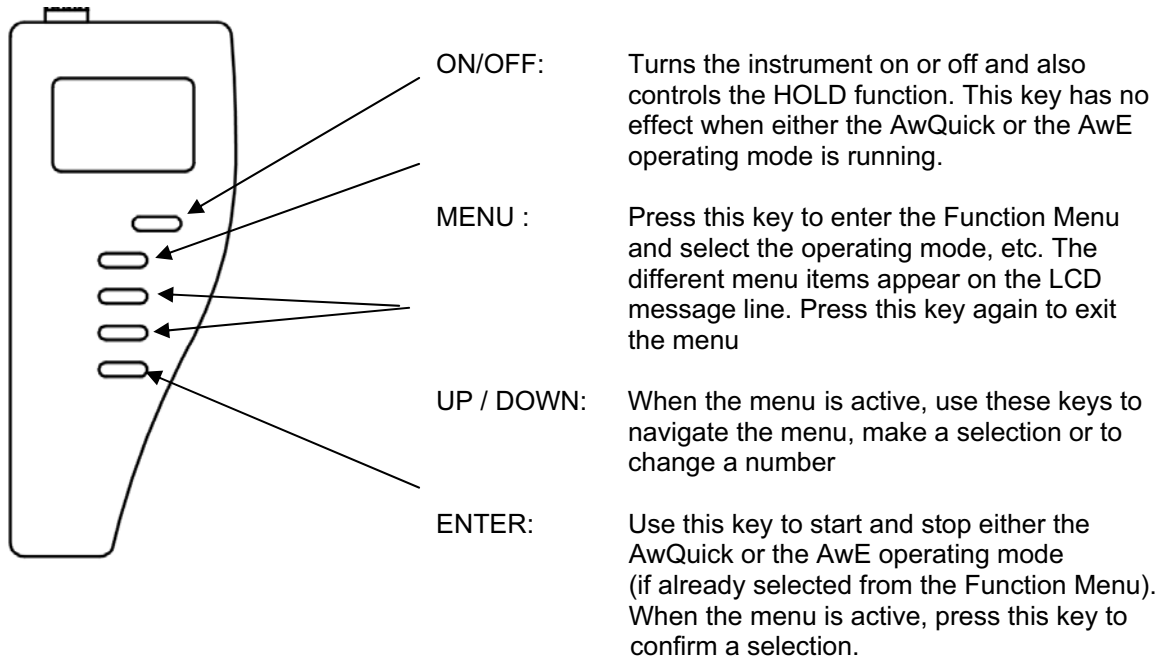

Temperature Unit

The temperature unit of the HygroPalm AW1 (°C or °F) is easily changed from the instrument keypad (see Settings).

Operation

Connect a probe to the HygroPalm AW1 and press on the ON/OFF key. After a brief test and introductory message, the instrument defaults to the “standard” mode (see Operating Modes). Measurements appear on the LC display and are updated to the display every 0.75 sec.

HOLD function: to freeze the measurements (Standard Mode only) press briefly on the ON/OFF key. Press again briefly on the key to return to normal operation.

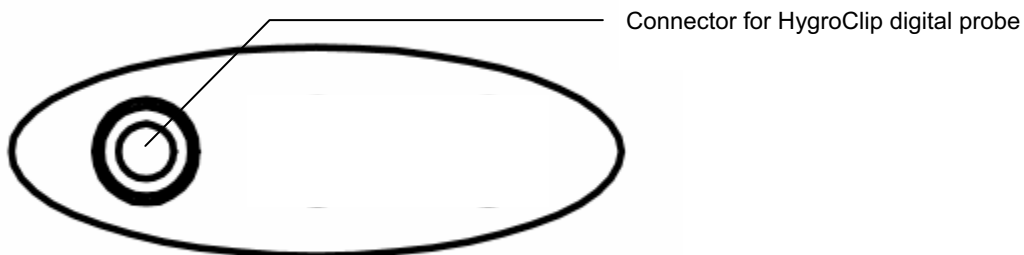

Operating Modes

The HygroPalm AW1 has 3 operating modes:

- **Standard Mode:** this mode is the default mode of the HygroPalm AW1. It is used for calibrating the probe above a reference humidity standard or to measure the full equilibration of a product (conventional water activity measurement). Both typically require from 30 to 60 minutes.

In the standard mode, the HygroPalm AW1 displays the water activity and temperature measured by the probe. Trend indicators appear one minute after powering up the instrument (up or down arrow to the left of the water activity and temperature values). These indicators are used to detect equilibrium conditions as required during probe calibration. The probe is at equilibrium when both the up and down arrow are displayed at the same time.

Upon powering the HygroPalm AW1, the instrument automatically defaults to the standard mode. If either the AwE or the AwQuick mode have been selected (see mode selection), the HygroPalm goes into the AwE or AwQuick mode as soon as the ENTER key is pressed. When neither the AwE mode nor the AwQuick mode are running, the HygroPalm AW1 returns temporarily to the standard mode.

- **AwE mode:** this mode is essentially the same as the standard mode with the difference that the HygroPalm AW1 automatically detects equilibrium conditions and ends the measurement at that time by freezing the display.

- **AwQuick mode:** this mode accelerates the water activity measurement and provides a result in typically 5 minutes. When temperature conditions are stable (both at the product and probe), the measurement obtained with the AwQuick mode is generally within ± 0.005 aw of the measurement that would be obtained by waiting for full equilibration of the product and probe.

Mode Selection

Note: upon being powered up, the HygroPalm AW1 remembers the last mode that was selected.

The operating mode of the HygroPalm AW1 is selected from the Function Menu. To select any of the 3 modes, proceed as follows:

- press the MENU key
- use the UP or DOWN arrow to display MODE on the LC display
- press the ENTER key to select the MENU function
- use the UP or DOWN arrow to display the desired mode
- press the ENTER key to select the mode

Depending on the mode that was selected, proceed as follows

a) Standard Mode:

No further action is required after selecting this mode. Simply proceed with the measurements.

b) **AwE Mode:**

Upon selecting this mode, the HygroPalm AW1 displays the following:

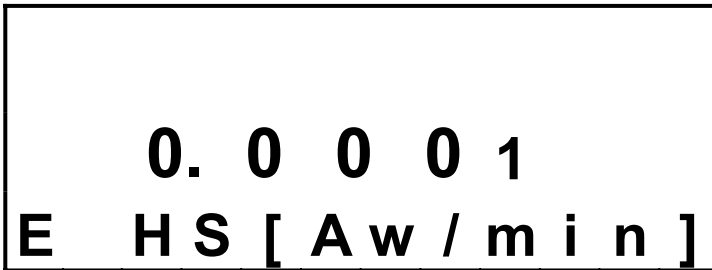

0. 0 0 0 1
E H S [A w / m i n]

Use the UP or DOWN arrow to set the definition of stable humidity. In the above example, the HygroPalm AW1 will consider humidity to be at equilibrium when the rate of change of the humidity signal is less than 0.0001 Aw per minute. Default value: 0.0001 Aw / min

Press the **ENTER** key to record and confirm this setting. The display now shows the following:

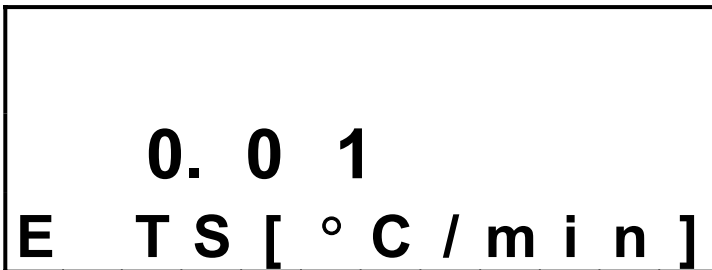

0. 0 1
E T S [° C / m i n]

Use the UP or DOWN arrow to set the definition of stable temperature. In the above example, the HygroLab will consider temperature to be at equilibrium when the rate of change of the temperature signal is less than 0.01 °C per minute. Default value: 0.01 °C / min

Press the **ENTER** key to record and confirm this setting. The AwE mode is now active.

When ready to measure, press the ENTER key to access and start the AwE mode. Press the ENTER key again to stop the AwE mode at any time and return to the Standard mode.

Notes:

- When the HygroPalm AW1 is in the AwE mode, pressing the ENTER key automatically starts the AwE mode, unless the MENU key was pressed immediately before pressing the ENTER key.
- The ON / OFF key is inoperative in the AwE mode. You must stop the AwE mode in order to be able to turn the power of with the red ON/OFF key.

For instructions on using the AwE mode, see Water Activity Measurement.

c) **AwQuick Mode:**

Upon selecting this mode, the HygroPalm AW1 displays the following:



Use the UP or DOWN arrow to set the dwell time. In the above example, the HygroPalm AW1 will wait 4 minutes before processing the humidity data with the AwQuick algorithm.

Default value: 4 min (recommended value)

Press the **ENTER** key to record and confirm this setting. The display now shows the following:



Use the UP or DOWN arrow to set the definition of stable temperature. In the above example, the HygroPalm AW1 will consider temperature to be stable when the rate of change of the temperature signal is less than 0.01 °C per minute.

Default value: 0.01 °C / min

Press the **ENTER** key to record and confirm this setting. The AwQuick mode is now active.

When ready to measure, press the ENTER key to access and start the AwQuick mode. Press the ENTER key again to stop the AwQuick mode at any time and return to the Standard mode.

Notes:

- When the HygroPalm AW1 is in the AwQuick mode, pressing the ENTER key automatically starts the AwQuick mode, unless the MENU key was pressed immediately before pressing the ENTER key.
- The ON / OFF key is inoperative in the AwQuick mode. You must stop the AwQuick mode in order to be able to turn the power of with the red ON/OFF key.

For instructions on using the AwQuick mode, see Water Activity Measurement.

Water Activity Measurement

Water Activity: definition and applications

Definitions

The moisture content of a product can be defined as the percentage weight of water in relation to the dry weight of the product.

Products in which moisture can be present can be classified in two categories: hygroscopic and non hygroscopic. Examples of hygroscopic materials are salts, vegetal fibers, most metal oxides, many polymers, etc. Examples of non hygroscopic products are metal powders, glass granules, etc.

Regarding the moisture content of a product, we define static equilibrium as a set of conditions under which the product does not exchange any moisture with its environment. Under conditions of static equilibrium, the moisture content of a hygroscopic product depends on the nature of the product and also on the two following factors:

- (a) the partial pressure of water vapor in the immediate environment of the product
- (b) the temperature of the product

If the moisture content of a product is not dependent on both these factors, then the product is not hygroscopic.

Hygroscopic products may absorb water in different ways: sorption with formation of a hydrate, binding by surface energy, diffusion of water molecules in the material structure, capillary condensation, formation of a solution, etc. Depending on the absorption process, water is bound to the product with more or less strength. Moisture content can include both an immobilized part (e.g. water of hydration) and an active part.

Water activity A_w (or equilibrium relative humidity %ERH) measures the vapor pressure generated by the moisture present in a hygroscopic product.

$A_w = p / p_s$ and $\%ERH = 100 \times A_w$, where:

p : partial pressure of water vapor at the surface of the product
 p_s : saturation pressure, or the partial pressure of water vapor above pure water at the product temperature

Water activity reflects the active part of moisture content or the part which, under normal circumstances, can be exchanged between the product and its environment.

Water activity is usually defined under static conditions of equilibrium. Under such conditions, the partial pressure of water vapor (p) at the surface of the product is equal to the partial pressure of water vapor in the immediate environment of the product. Any exchange of moisture between the product and its environment is driven by a difference between these two partial pressures.

Finally, water vapor can also be present in a gas or gas mixture. The relative humidity of a gas is defined as $\%RH = 100 \times p/p_s$, where (p) is the partial pressure of the water vapor present in the gas mixture and (p_s) is the saturation pressure, or the partial pressure of water vapor above pure water at the temperature of the gas.

Aw and Temperature

Both water activity (materials) and relative humidity (gases) are referred to the saturation pressure (p_s) or partial pressure of water vapor above pure water:

$$A_w = p / p_s$$

$$\%RH = 100 \times p/p_s$$

The saturation pressure (p_s) is strongly dependent on temperature. At normal room temperature, (p_s) increases by about 6.2% for a 1°C increase in temperature. In an open environment that is not saturated with water vapor, the partial pressure of water vapor (p) does not change with temperature. In a closed environment, (p) changes proportionally to the °K temperature (°K temperature = °C temperature + 273.16). At normal room temperature, the change in (p) caused by a small change in the °C temperature is practically negligible. Because (p) does not change with temperature while (p_s) does, the relative humidity of a gas (%RH = 100 x p/p_s) is strongly temperature dependent. At 95 %RH and room temperature, an increase of 1°C results in a relative humidity decrease of about 6 %RH. At 50%RH, the same temperature increase causes relative humidity to decrease by about 3 %RH.

The water activity of most hygroscopic products is not as strongly dependent on temperature. At room conditions, research data typically shows that water activity varies only by roughly 0.0005 to 0.005 A_w (0.05 to 0.5 %RH) when temperature changes by 1°C.

This is explained by the fact that the partial pressure (p) at the surface of a hygroscopic product does vary with temperature. Above most hygroscopic products, the magnitude of the change in the partial pressure of water vapor (p) with temperature is similar (but not exactly equal) to the magnitude of the change of the saturation pressure (p_s) above pure water.

In summary, a change in temperature causes the partial pressure of water vapor above a hygroscopic product to change. At the same time, the partial pressure in the air above the product is practically unchanged. It follows that any change in the temperature of a hygroscopic product automatically causes the product to exchange moisture with the air (or gas) that surrounds it. Moisture is exchanged until the partial water vapor pressure at the surface of the product and in the air are equal. When measuring water activity, it is essential to keep temperature as constant as possible.

Applications

The active part of moisture content and, therefore, water activity, provide better information than the total moisture content regarding the micro-biological, chemical and enzymatic stability of perishable products such as foods and seeds. For similar reasons, water activity is equally relevant in the pharmaceutical industry where it provides useful information regarding the cohesion of tablets and pills, or the adherence of coatings. Water activity can be directly compared with the relative humidity of the ambient air to prevent dimensional changes in a product (paper, photographic film), to prevent hygroscopic powders (powdered sugar, salt) from caking or turning into a solid block, etc

Water activity can be used with some products (mostly synthetic products) as a means of indirectly measuring the total moisture content. This requires developing sorption isotherms to this purpose. Sorption isotherms are graphs that provide the relationship between water activity and moisture content at constant temperature. For most natural products, repeatable sorption isotherms cannot be reliably developed and water activity should be regarded as separate from moisture content.

Principle of Measurement

The standard (or conventional) method of measuring water activity consists in placing a sample of the product to be measured in a sealed container. The product sample slowly exchanges moisture with the air inside the sealed container until equilibrium is reached. Experience shows that even with a relatively small amount of product, it is the moisture contained in the product that ends up determining the humidity of the air, and not vice versa.

As an alternative, it is also possible to insert a probe in the product (insertion probe).

The equilibration process is monitored by measuring the humidity of the air above the product with a relative humidity sensor ($\%RH = 100 \times A_w$). Because temperature is an important factor when measuring water activity, the temperature of the air above the product, is also monitored.

By definition, water activity is equal to $\%RH / 100$ when equilibrium has been reached. At that time, the product no longer interchanges moisture with the surrounding air.

The following uses the Rotronic AW-DIO water activity probe as an example.

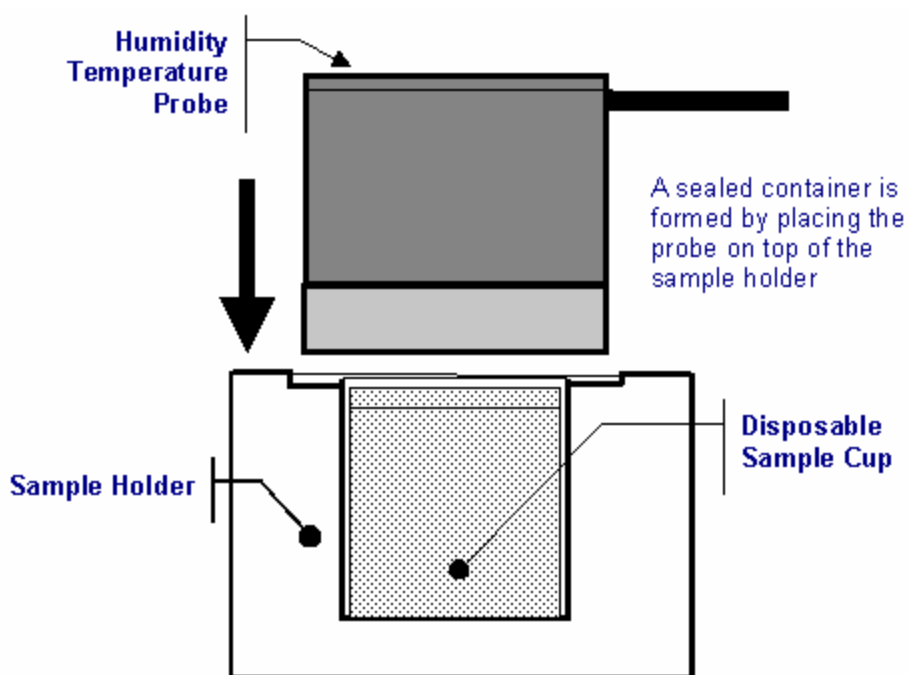

General Recommendations

1. Preparation of the product samples

The AwVC-DIO probe can be used with two different sample holders (WP-14: shallow / WP-40: deep), corresponding to two sizes of disposable sample cups (PS-14: shallow / PS-40: deep). Use the shallow sample cups (PS-14) and the shallow sample holder (WP-14) for calibrating the probe with the Rotronic certified humidity standards or with saturated salt solutions. In general, use the shallow cups for a liquid, a paste or a powder. Use the deep sample cups (PS-40) and

the deep sample holder (WP-40) for products in bulk (large chunks).

The disposable sample cups serve two purposes:

- (a) provide a means storing product samples prior to measurements so that they can come to the same temperature as the probe
- (b) prevent contamination across samples.

Prior to measurements, fill a number of disposable sample cup with the products to be measured. **Usually, filling up to 1/3 of the cup is sufficient.** To avoid soiling the probe, do not fill the cup above the fill line (see below).

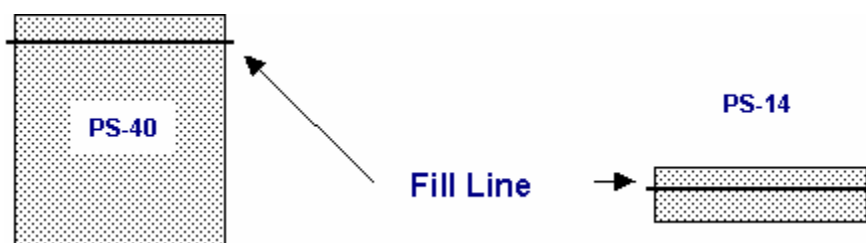

2. Other basic guidelines

To ensure accurate and repeatable results, please follow these basic guidelines:

a) Measure water activity only in a temperature stable area. This is an essential requirement! Do not measure on a bench that is located near a heater, an AC vent or an open window. Avoid direct exposure of the probe and/or product samples to sun light (heating effect). For best accuracy, temperature should not change by more than 0.01°C / minute (0.0075 °C / minute in the case of product with a water activity > 0.80 aw)

b) Prior to measurements, place each product sample in a disposable sample cup with the cover on. Place the cups in the same general area as the probe. Allow for sufficient time for the samples to come to the temperature of the probe (usually room temperature). A frequent mistake is to measure product samples which have been kept overnight in a refrigerator without first allowing them to come to room temperature. Another mistake is to measure hot samples coming straight from the manufacturing process. To measure water activity at a temperature other than room temperature, place both the probe and the product samples in an incubator set at the desired temperature.

c) Avoid warming up the probe, the sample holder or the product sample by touching or holding for too long in your hand.

d) When using either the AW-DIO or the AwVC-DIO probe, check that the probe is on (this is the default when powering up the HygroPalm AW1). When the probe is on, the red LED on the top of the probe should be flashing. The probe does not operate and the HygroPalm AW1 does not get any signal when the LED is not on. If necessary, press once on the red button located on top of the probe.

Using the AwQuick Mode

In the AwQuick mode, the HygroPalm AW1 uses an algorithm to project the full equilibrium value (water activity) of the product sample. The measurement is automatically ended and typically requires about 5 minutes.

The HygroPalm AW1 performs the following tasks:

- 1) the value of the humidity signal is constantly monitored
- 2) the stability of the temperature signal is constantly monitored
- 3) After an initial period of time (dwell time), the humidity data is used to project the end value of the equilibration process (water activity). The measurement ends automatically as soon as the projected Aw value is stable. At that time, the HygroPalm freezes the display.

With the default dwell time of 4 minutes, measurements typically require about 5 minutes. The difference between the AwQuick mode and the full product equilibrium is typically 0.005 aw or less. The value of the dwell time can be set by the user (see SETTINGS). This value represents a trade off between speed of measurement and accuracy. Generally, a longer dwell time produces more accurate results but causes measurements to take longer.

The value of temperature is the average temperature during the measurement. The HygroPalm AW1 displays a trend indicator to the left of the temperature value. This is used to verify that temperature is stable during the measurement.

When ready to measure:

1. Press on the ENTER key on the keypad of the HygroPalm AW1. The display shows::

Note: numerical values are for illustration purposes only.

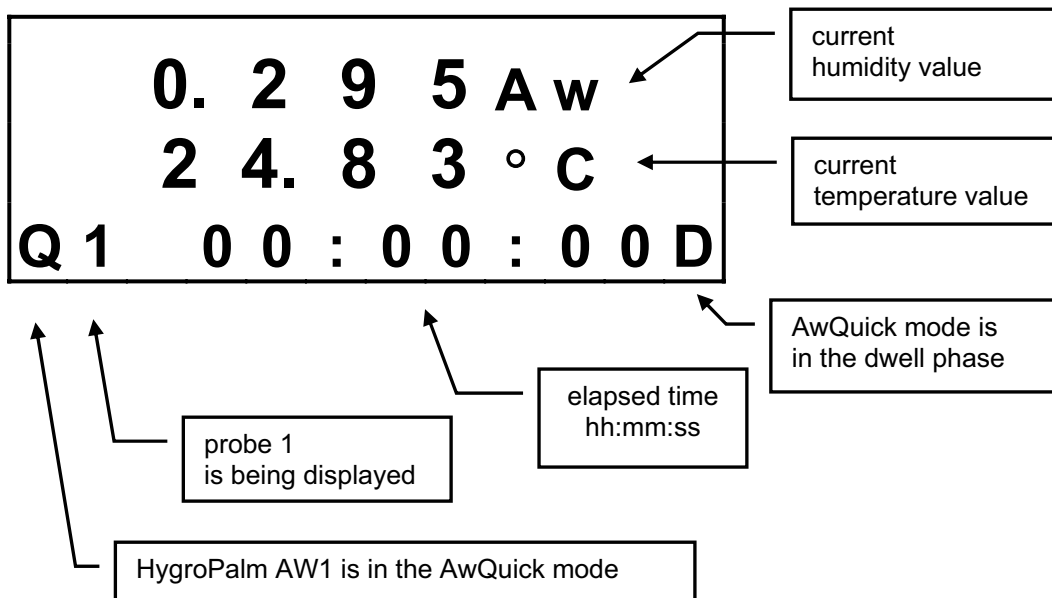

After 60 seconds, the trend indicator appears for temperature. Two arrows (up and down) mean stable signal, as per the setting defined for the AwQuick mode (see Function Menu, Settings) :

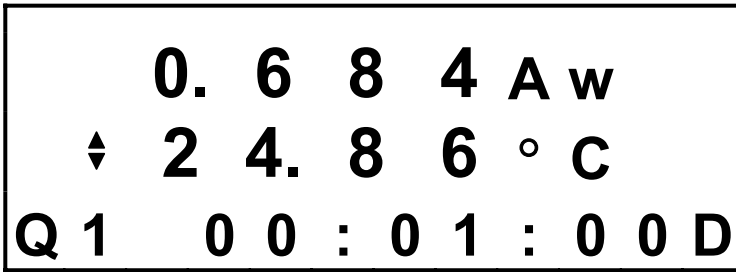

At the end of the dwell time, the display changes as follows:

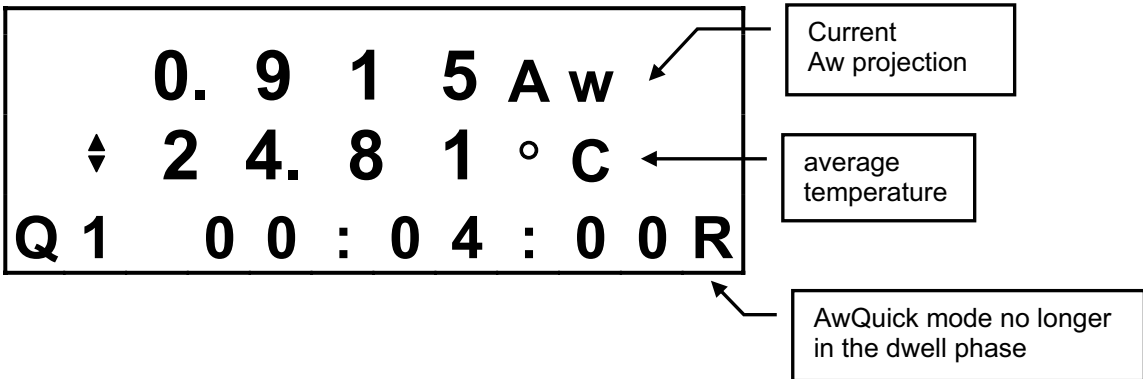

When the projected value of Aw is stable, the HygroPalm AW1 freezes the display. Black rectangles to the left of the display indicate that the measurement is ended.

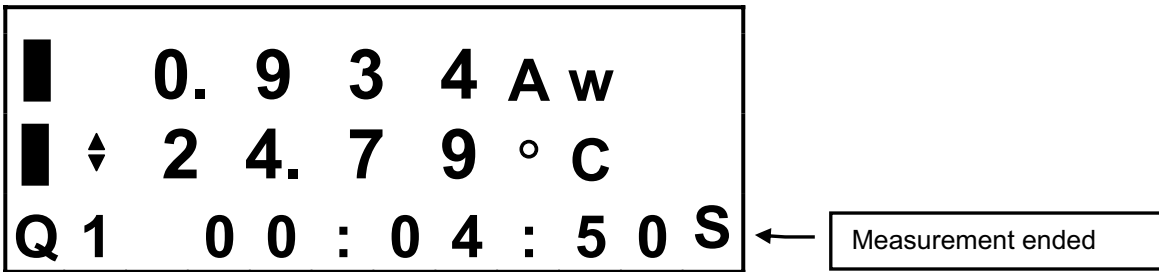

Press the **ENTER** key to exit this screen. Press **ENTER** again to start a new measurement.

Using the AwE Mode

In the AwE mode, the HygroPalm AW1 monitors the water activity and temperature values. When both values are at equilibrium during a few minutes, the measurement is automatically ended. Depending both on the product being measured and on the stability of temperature, measurements typically require 30 to 60 minutes.

When ready to measure:

1. Press on the **ENTER** key. The display shows:

Note: the numerical values are for illustrative purposes only.

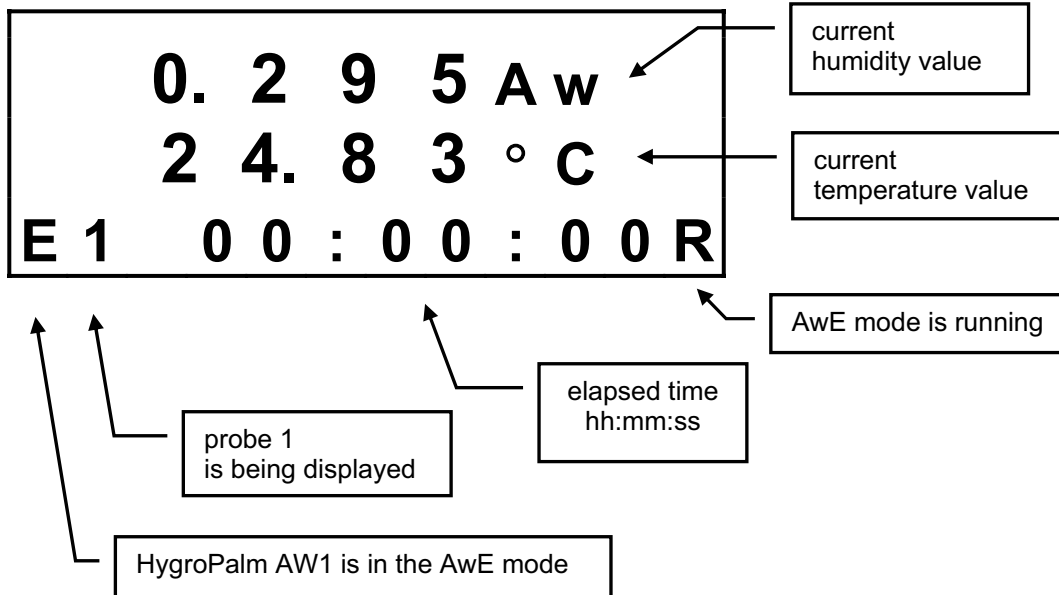

After 60 seconds, the trend indicators appear both for humidity and temperature. Two arrows mean stable signal, as per the settings defined when selecting the AwE mode :

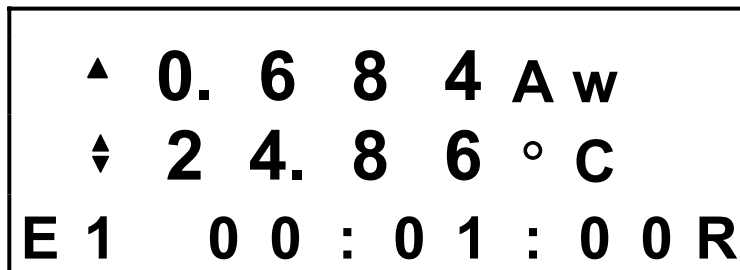

Upon reaching and holding equilibrium for a few minutes, the HygroPalm AW1 freezes the display. Black rectangles to the left of the display indicate that the measurement is ended.

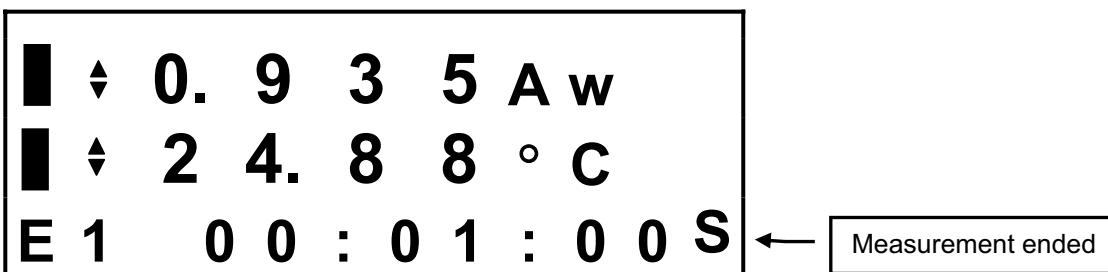

Press the **ENTER** key to exit this screen. Press **ENTER** again to start a new measurement.

Function Menu

To access the function menu, press the MENU key. The first menu item appears on the message line of the LC display. Use the UP or the DOWN key to navigate the menu. When the desired menu item appears on the message line of the LC display, press the ENTER key to select. Some menu items have sub-items. These can be selected with the UP, DOWN and ENTER keys. To exit the menu and return to the normal display mode, press the MENU key. The instrument also returns automatically to the normal display mode when no key is being pressed for some time (main menu: 10 sec., submenu: 30 sec.). The HygroPalm AW1 menu includes the following items:

- MODE
- ADJUST MPT
- ADJUST 1PT
- SETTINGS
- PROBE
- SYS STATUS

MODE

Definition

The MODE function is used to select the operating mode of the HygroPalm AW1.

Selections

The MODE function offers the following choices (use the UP and DOWN keys):

- Standard:** Default operating mode
Q AwQuick: Accelerated water activity measurement
E AwE: Conventional water activity measurement with automatic detection of full equilibrium.

1) For detailed instructions, please refer to Mode Selection, earlier in this manual.

ADJUST M.PT (full probe calibration against a reference)

Definition

The Adjust M.PT function permits the full calibration of the ROTRONIC HygroClip digital probe against a known reference environment. This function is designed to permit calibration at 2 temperature values and at up to 4 relative humidity values.

Note:

Water activity calibration is actually a calibration of the relative humidity signal provided by the probe. The parameter used is relative humidity which is equal to $100 \times aw$. For example, $1.00 aw = 100 \%RH$.

Selections

The Adjust M.PT function offers the following choices (use the UP and DOWN keys):

RHS: Humidity calibration using the ROTRONIC Humidity Standards ¹⁾
Humidity: Humidity calibration using any suitable reference environment
Temperature: Temperature calibration using any suitable reference environment

1) For humidity calibration, ROTRONIC offers convenient, certified humidity standards to generate known humidity values (for more details, see Appendix 3 - Humidity Calibration).

Procedure

Please be sure to observe the following rules:

- a) Always calibrate temperature first (if temperature needs to be calibrated)
- b) When calibrating temperature (2 points), always calibrate at the low value first. The instrument is programmed to use the low temperature value to compute the offset and the high temperature value to compute the gain.

T-low < 70 °C (158°F) : used to compute the calibration offset

T-high ≥ 70 °C (158 °F) : used to compute the calibration gain

For best accuracy, we recommend using a T-low value close to 20°C (68°F). Preferably, the difference between T-high and T-low should be at least 50 °C (90 °F)

When calibrating humidity (2, 3 or 4 points) with the ROTRONIC humidity standards, always follow the sequence 35 %RH, 80 %RH, 10 %RH or 5 %RH, 0 %RH. When using a reference other than the ROTRONIC humidity standards, use reference conditions that are within the following brackets and observe the sequence:

>25 %RH...≤55 %RH ¹⁾ : used to compute the calibration offset

>55 %RH ¹⁾ : used to compute the calibration gain

>1 %RH...≤25 %RH : sensor linearity adjustment

≤ 1 %RH : sensor linearity adjustment

The HygroPalm AW1 is programmed to automatically recognize these brackets.

1) For best accuracy, we recommend using values close to 35 %RH and 80 %RH

Prior to using the Adjust M.PT function, monitor the water activity and temperature readings in the Standard Mode. Wait for the trend indicators to show stable conditions both for water activity and temperature. When the probe is at equilibrium, activate the Adjust M.PT function and make the appropriate selections:

- a) **RHS:** press the ENTER key to select this item. The LC display shows the value read by the probe at the time the ENTER key was pressed. The letters "RHS" are displayed on the message line. Use the UP or the DOWN key to change the humidity value to match the mean value (at 23°C) written on the certificate supplied with the standard. For a faster change, keep the key pressed down. Press the ENTER key when done.

Note: in the RHS mode, the software automatically compensates for the effect of temperature on the humidity standard. No additional correction is required.

- b) **Humidity or Temperature:** press the ENTER key to select. The LC display shows the value read by the probe at the time the ENTER key was pressed. The word "humidity" or "Temperature" is shown on the message line. Use the UP or the DOWN key to change the humidity or temperature value to match the value of the reference environment. For a faster change, keep the key pressed down. Press the ENTER key when done.

After pressing the ENTER key, the message "sure?" should appear on the LC display. Press ENTER to confirm. Next, the LC display will confirm that the probe adjustment has been successfully completed. At that time, press ENTER to exit or MENU to return to the function Adjust M.PT and do another calibration point.

Carry on in the same manner for each calibration point, following the sequence described above.

Note: you can exit the function at any time (without calibrating the probe) by pressing the MENU key.

ADJUST 1PT (1-point adjustment against a reference)

Definition

The Adjust 1PT function permits to do a 1-point adjustment (temperature or humidity) of the ROTRONIC HygroClip digital probe against a known reference environment. This function is limited to a simple offset adjustment that is applied across the entire measuring range.

Notes:

Water activity calibration is actually a calibration of the relative humidity signal provided by the probe. The parameter used is relative humidity which is equal to $100 \times a_w$. For example, $1.00 a_w = 100 \%RH$.

A 1-point adjustment is no substitute for a full calibration (2 or more points). Doing a 1-point adjustment can improve accuracy over a narrow range of conditions and may also be detrimental to accuracy at other conditions.

Selections

The Adjust 1PT function offers the following choices (use the UP and DOWN keys):

RHS: Humidity calibration using the ROTRONIC Humidity Standards ¹⁾
Humidity: Humidity calibration using any suitable reference environment
Temperature: Temperature calibration using any suitable reference environment

1) For humidity calibration, ROTRONIC offers convenient, certified humidity standards that generate known humidity values (for more details, see Appendix 3 - Humidity Calibration).

Procedure

Prior to using the Adjust 1PT function, monitor the water activity and temperature readings in the Standard Mode. Wait for the trend indicators to show stable conditions both for water activity and temperature. When the probe is at equilibrium, activate the Adjust 1PT function and make the appropriate selections:

- a) **RHS:** press the ENTER key to select this item. The LC display shows the value read by the probe at the time the ENTER key was pressed. The letters "RHS" are displayed on the message line. Use the UP or the DOWN key to change the humidity value to match the mean value (at 23°C) written on the certificate supplied with the standard. For a faster change, keep the key pressed down. Press the ENTER key when done.

Note: in the RHS mode, the software automatically compensates for the effect of temperature on the humidity standard. No additional correction is required.

- b) **Humidity or Temperature:** press the ENTER key to select. The LC display shows the value read by the probe at the time the ENTER key was pressed. The word "humidity" or "Temperature" is shown on the message line. Use the UP or the DOWN key to change the humidity or temperature value to the value of the reference environment. For a faster change, keep the key pressed down. Press the ENTER key when done.

After pressing the ENTER key, the message "sure?" should appear on the LC display. Press ENTER to confirm. Next, the LC display will confirm that the probe adjustment has been successfully completed. At that time, press ENTER to exit.

Note: you can exit the function at any time (without calibrating the probe) by pressing the MENU key.

SETTINGS

Definition

This function is used to do the following:

- turn the trend indicators on or off
- change the symbol used for relative humidity or to display humidity as water activity (a_w)
- turn the battery charge function on or off (do not set to “on” when using a standard battery)
- select between the Metric or English unit system

Procedure

Trend: use the UP or the DOWN key to enable or disable the trend indicators.

The trend of humidity and temperature is shown on the display by an arrow (up or down) to the left of the measured value. Both arrows are shown to indicate stable conditions. Stable conditions are defined as rate of change of less than 0.02 %RH / min or °C / min.

Signal stability is first evaluated after 60 seconds into the measurement and is updated every 30 seconds.

Humi Unit: use the UP or the DOWN key to change the symbol used for relative humidity (depends on country and language) or to display humidity as water activity.

Accu Charge: the battery charge function should always be turned off when the instrument is powered with a standard battery. To enable or disable the battery charge function: select Accu Charge and press ENTER. Select Off or On. Press ENTER to effect the change.

Units: use the UP or the DOWN arrow key to toggle between Metric (°C) and English (°F).

PROBE

Definition

This function displays the version number and serial number of the ROTRONIC HygroClip digital probe connected to the instrument.

Procedure

When entering the function, the version number of the probe is displayed first. Use the UP or the DOWN key to display the serial number of the probe.

SYS STATUS

Definition

This function displays the software version of the instrument, any user defined description for the instrument (requires the optional HW3 software) and the serial number of the instrument.

Procedure

When entering the function, the software version number is displayed first. Use the UP or the DOWN key to display the other data.

Errors and Status Messages

The following is a list of coded messages (101, etc.) that the HygroPalm may show on the bottom line of the LC display.

Errors:		
101	checksum error	the checksum test did not pass during RS-communication.
102	bad command	an unknown command was received
103	disallowed command	a command was received that is reserved for production and service
104	unknown probe input	reference was made to a non-existing analog or digital probe input
105	argument error	error in the number of the arguments in the command or in the value of one of the arguments
106	HygroClip communication error	the HygroClip probe does not answer or is not connected
107	calibration error	the difference between the probe reading and the calibration point is larger than the maximum allowed by the INI command.
108	calibration error (overflow)	internal probe error (or the difference between the probe reading and the calibration value is too large)
110	unknown reference probe	the reference probe is not connected or the reference probe input does not exist
111	Temperature error	During humidity calibration, temperature should be within the limits of 0 and 80°C (32 and 176°F)

Warnings:		
120	no adjustment	calibration
121	No HygroClip probe is connected	

Status:		
130	the probe was adjusted	calibration

Environmental Limits

The HygroPalm AW1 can operate in the temperature range of -10..50°C (14...122°F) and should not be exposed to condensing humidity.

Maintenance

The HygroPalm AW1 should not require any routine maintenance other than replacing the battery. See **appendix 2 and appendix 3** regarding the maintenance of the probes used with the HygroPalm AW1.

Specifications

Operation		9 V alkaline battery 12...15V AC adapter (100 mA) C(+) Tip 9 V rechargeable battery 110 mAh
Max. current consumption		30 mA
Operating limits at electronics		0...99 %RH (non condensing) -10...50°C (14...122°F)
<i>Measured parameters</i> ¹		
water activity	indication range	0.000...1.000 aw
temperature	indication range	-99.9...999.9 °C or °F
System accuracy at 23°C/73°F with HygroClip probe & 4-point calibration		± 0.015 aw ± 0.2°C / 0.4°F
Number of probe inputs		1
Probe type		ROTRONIC HygroClip digital probe
Display		Alphanumerical LC display
Battery status		Automatic Indication
HOLD function		Briefly push the ON/OFF Button
Housing material		ABS
Housing dimensions		230 x 80 x 30 mm (9.05 x 3.15 x 1.18")
Weight (w/o probe)		200 g (0.44 lb)

Appendix 1: Practical Advice for Measuring Aw

When measuring water activity, the main concerns should be (a) the water activity and temperature stability of the product sample and (b) the stability of temperature at the probe. Beware of product samples that have been refrigerated and beware of product sample that have been freshly taken from the production line. In both cases, the sample temperature may require a few hours to stabilize. At a water activity of 0.50 aw, a temperature difference of 1°C (1.8 °F) between the probe and the product typically results in an error of 0.03 aw. At higher values of water activity, the same temperature difference may cause an error of 0.006 aw.

Factors that influence the accuracy of the AwQuick mode

On average, the difference between the AwQuick mode and full product equilibrium is less than ± 0.005 aw (± 0.5 %RH). However, the difference can be sometimes much higher.

A large difference between the AwQuick mode and full equilibrium does not necessarily mean that the AwQuick mode is unreliable or inaccurate. A large difference means that factors have intervened after the completion of the AwQuick mode that could not be anticipated while this mode was running:

a) Lack of temperature stability during the measurement

Without temperature control of the probe and environment, temperature tends to change during the relatively long time required by the AWE mode. In turn this affects any comparison between the result of the AWQ mode and the result of the AWE mode. Samples with a high water activity are particularly sensitive to the effect of a change in temperature both regarding the probe and the sample itself.

An inversion in the trend of temperature causes particular problems. When the trend of temperature changes during the measurement, a false equilibrium may appear for some time and this can potentially fool the AwQuick mode.

A frequent problem has to do with the measurement of product samples that have been refrigerated. Refrigerated product samples can take several hours to come to real equilibrium with room temperature and the water activity of these samples varies as the sample temperature changes.

b) Inherently unstable product samples

Some product samples are inherently unstable and are problematic to measure. Typically the water activity of the sample goes through successive stages of quasi equilibrium while the actual end value of water activity keeps creeping at a very slow rate.

Products with a high oil content are an example of this: during the measurement, the oil tends to separate from the rest of the sample and to float at the top of the sample, thus changing the water activity of the sample (example: pesto sauce).

Another example are products with a high affinity for water. Even during a full equilibrium measurement, water activity may keep creeping very slowly up from an initial apparent equilibrium.

Other products that are hard to measure are non homogeneous products such as puffed rice, cookies with fruit filling and sausage. Unless they are pre-homogenized, such products equilibrate very slowly and the AwQuick results tend to be less accurate than with other products.

Factors that influence the time taken to reach full equilibrium

In addition to the factors mentioned above, the time required for a measurement at full equilibrium is obviously very much affected by any change in the temperature of the probe and sample. At full equilibrium the value both aw and temperature should be stable for several minutes.

When measuring samples with very low water activity, it may make sense to relax the definition of temperature equilibrium. This should lead to results in a shorter time.

Appendix 2: Maintenance of the ROTRONIC probes

Cleaning or Replacing the Dust Filter of the Probe

The dust filter used to protect the probe sensors should be kept clean. When the filter is dirty, it should be removed from the probe. Do not clean the filter while it is on the probe, especially if using a cleaning agent. Corroded, discolored or clogged filters should be replaced.

a) Insertion probe HP28:

Unscrew the pointed end of the probe and slide out the dust filter

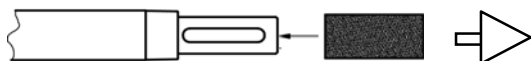

b) AW-DIO and AwVC-DIO

The dust filter is held in place by a snap ring. Use snap-ring pliers to free the filter for removal. Be careful not to touch the sensors while they are not protected by the dust filter.

Periodic Calibration Check of the Probes

Long term stability of the ROTRONIC Hygromer humidity sensor is typically better than 1 %RH per year. For maximum accuracy, calibration of the probe should be verified every 6 to 12 months. Applications where the probe is exposed to significant pollution may require more frequent verifications.

Both the Pt 100 RTD temperature sensor and associated electronics are very stable and should not require any calibration after the initial factory adjustment. For routine calibration checks, the probe should be verified at one or two values of humidity. For more details, see **appendix 3 - Calibration Basics and Functions – ADJUST M.PT.**

For users who do not want to get involved with field calibrations, our unique probe exchange program offers an attractive alternative. This program takes advantage of the interchangeability of the ROTRONIC HygroClip digital probes. Replacement probes are fully calibrated and are rehabilitated probes with a brand new humidity sensor and filter.

Appendix 3: Calibration Basics

The following choices are available to calibrate the probe(s) used with the HygroPalm AW1:

- a) Calibration using the HygroPalm AW1 display and keypad (see Functions).
- b) Calibration of the probe alone (removed from the HygroPalm AW1), using a PC with the optional HW3 software and the MOK-WIN calibration cable (see separate instructions for the HW3 software).

Note: the HygroPalm AW1 itself should not require any field calibration.

Temperature Calibration

Note: the stability of the Pt100 RTD sensor used to measure temperature is such that temperature calibration in the field is seldom required.

In order to be able to correctly evaluate the accuracy of the temperature measurements provided by the probe, you should be able to meet the following requirements:

- a) Both the probe and a reference thermometer should be ventilated with the same stream of air. Any dust filter used to protect the sensors should be carefully removed from the probe. If the probe has a protective slotted cap, this may be left on the probe.
- b) Air velocity at the sensor should be within the limits of 200 to 500 feet/minute (1 to 2.5 meters/second). Any comparison between two instruments at a velocity under 200 feet/minute may not be valid. Air velocity above 500 feet/minute may damage the unprotected humidity sensor.
- c) The temperature of the air stream should be practically constant.

If you cannot meet the above requirements, you should not attempt to calibrate temperature.

Humidity Calibration

ROTRONIC provides easy-to-use, certified humidity standards for those customer who do not have access to a humidity generator. To use these standards, you will need a calibration device that is suitable for your probe.

Calibration Device

The calibration device is a small airtight container that fits on the probe and seals around the humidity sensor. During calibration, a known reference humidity is produced inside the calibration device by means of a humidity standard (usually an aqueous salt solution).

The following calibration devices are available from ROTRONIC:

- ER-15: for 15mm diameter probes
- ER-05: for 5mm diameter probes.

Certified Humidity Standards

The ROTRONIC certified standards are available in boxes of 5 glass ampoules of the same value, which can be stored indefinitely. Standards in the range of 5 to 95 %RH are non-saturated aqueous salt solutions that are precisely titrated at our factory for the right concentration. The 0 %RH humidity standard is made of small granules of a highly porous ceramic that have been dried at a high temperature. A Material Safety Data Sheet is available for each standard. Since most standards are a salt solution, parts which have come in contact with the liquid should be cleaned after each use.

Each box of standards comes with a certificate that provides statistical information on the manufacturing batch of the standard. Information on the effect of temperature on each standard is provided on the cover of each box of standard. When calibrating either with the HygroPalm AW1 or with the HW3 software, the effect of temperature on the standards is compensated by the software and no further correction is required. The value of the standards is not affected by altitude.

Instructions for using the Standards

- Install the calibration device on the probe so that the receptacle (or solution holder) is under the probe. Check for a tight fit and remove the receptacle from the calibration device.
- Place one fiber disc (each box of standards includes 5 discs) in the receptacle of the calibration device. The purpose of this disc is to prevent accidental spilling of the solution inside the calibration device or on the humidity sensor.
- Tap the top of the ampoule so that all liquid drops to the bottom of the ampoule. Snap off top and empty contents on fiber disc. Since the ampoule is made of glass, exercise proper caution (gloves, safety glasses) when snapping off the top.
- Put the receptacle back on the calibration device and make sure that the solution does not come in contact with the sensor: The solution inside the calibration device should never be on top of the sensors.
- Allow at least 60 minutes to insure that the calibration device, the solution and the sensor are in a state of equilibrium. This is verified by monitoring the display.
- After adjusting the probe, remove the receptacle from the calibration device. Throw away the wet disc (non reusable). Thoroughly wash and wipe dry the receptacle.

General Recommendations

During calibration, temperature stability is the single most important requirement. If possible, calibrate the probe is room temperature (18 to 25°C). Room temperature should be stable to $\pm 0.25^\circ\text{C}$ or better during the period of time required for each calibration point. Do not calibrate close to an air vent or a heater, in direct exposure to sun rays, etc.

If using a humidity generator to calibrate the probe, make sure that the probe is as fully immersed in the generator as possible to minimize temperature effects.

Appendix 4: Accessories and spare parts

Order Code	Description
PalmDock	Docking station for battery charging and RS232 communication (consult your local distributor regarding the 9VDC adapter)
MOK-01-B5	Adapter cable for HygroClip probes with DAT05 connector, compatible with 2 nd probe input of HygroPalm 2 or 3. Cable length 1 meter (3.2 ft)
MOK-03-WIN	Calibration cable for HygroClip probes with DAT05 connector. Terminated with a 25-pin SUB-D connector. Converter 25-pin to 9-pin is supplied. Cable length 3 meter (9.8 ft). 9VDC adapter may be required (consult your local distributor)
B5-03-WIN	Calibration cable for HygroClip probes with B5 connector. Terminated with a 25-pin SUB-D connector. Converter 25-pin to 9-pin is supplied. Cable length 3 meter (9.8 ft). 9VDC adapter may be required (consult your local distributor)
WP-14S	Sample Holder (14 mm deep) for use with the AW_DIO and AwVC-DIO probes
WP-40S	Sample Holder (40 mm deep) for use with the AW_DIO and AwVC-DIO probes
PS14	Pk of 100 disposable sample cups for use with the WP-14S
PS40	Pk of 100 disposable sample cups for use with the WP-40S
EA00-SCS	0%RH humidity std, SCS cert., pack of 5
EA05-SCS	5%RH humidity std, SCS cert., pack of 5
EA10-SCS	10%RH humidity std, SCS cert., pack of 5
EA11-SCS	11%RH humidity std, SCS cert., pack of 5
EA20-SCS	20%RH humidity std, SCS cert., pack of 5
EA35-SCS	35%RH humidity std, SCS cert., pack of 5
EA50-SCS	50%RH humidity std, SCS cert., pack of 5
EA65-SCS	65%RH humidity std, SCS cert., pack of 5
EA75-SCS	75%RH humidity std, SCS cert., pack of 5
EA80-SCS	80%RH humidity std, SCS cert., pack of 5
EA95-SCS	95%RH humidity std, SCS cert., pack of 5
ER-15	calibration device for 15mm dia. Probes
ER-05	calibration device for 5mm dia. Probes
ET-Z10	Sintered steel dust filter for HP28 insertion probe
W37	Filter set (wire mesh filter and snap ring) for AwVC-DIO probe
W24	Filter set (wire mesh filter and snap ring) for AW-DIO probe