

DIN W48 × H48mm, Universal voltage multi-function timer

Upgrade

Features

- Realization of wide range of power supply
: 100–240VAC 50/60Hz / 24–240VDC,
24VAC 50/60Hz / 24VDC, 12VDC
- Various output operation (6 kinds modes)
- Multi time range (16 kinds of time range)
- Wide control time (0.05sec. to 100hour)
- Easy setting of time, time range, output operation mode
- Easy to check output status by LED display



⚠ Please read "Caution for your safety" in operation manual before using.



Ordering information

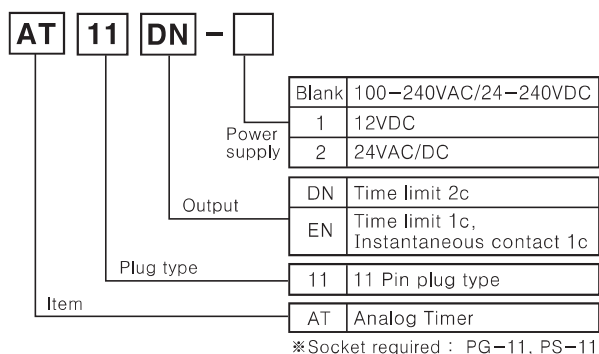
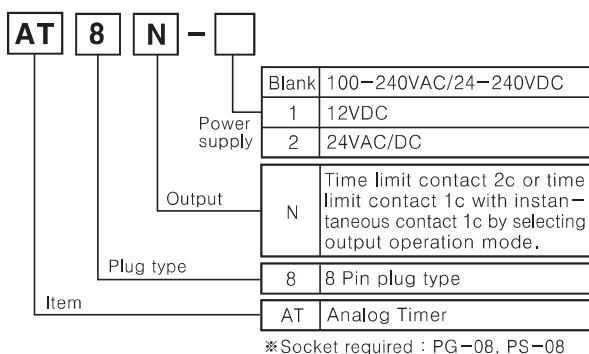

Specifications

Model	AT8N-□	AT11EN-□	AT11DN-□	
Function	Multi function timer			
Control time setting range	0.05 sec. to 100 hour			
Power supply	• 100–240VAC 50/60Hz, 24–240VDC • 24VAC 50/60Hz, 24VDC • 12VDC			
Allowable voltage range	90 to 110% of rated voltage			
Power consumption	• 100–240VAC : 4.3VA, 24–240VDC : 2W • 24VAC : 4.5VA, 24VDC : 2W • 12VDC : 1.5W		• 100–240VAC:3.5VA, 24–240VDC:1.5W • 24VAC:4VA, 24VDC:1.5 • 12VDC:1W	
Reset time	Max. 100ms			
Min. input signal width	START input	—	Min. 50ms	
	INHIBIT input			
	RESET input			
Input	START input	—	No-voltage input ^(*) Short-circuit impedance : Max. 1kΩ Residual voltage : Max. 0.5V Open-circuit impedance : Min. 100kΩ	
	INHIBIT input			
	RESET input			
Timing operation	Power ON start type	Signal ON Start type		
Control output	Contact type	Time limit DPDT (2c), Time limit DPDT (1c) + Instantaneous DPDT (1c) by selecting output operation mode	Time limit SPDT (1c), Instantaneous SPDT (1c)	Time limit DPDT (2c)
	Contact capacity	250VAC 5A resistive load		
Relay life cycle	Mechanical	Min. 10,000,000 operations		
	Electrical	Min. 100,000 operations (250VAC 5A resistive load)		
Repeat error	Max. ±0.2 % ±10ms			
SET error	Max. ±5% ±50ms			
Voltage error	Max. ±0.5%			
Temperature error	Max. ±2%			
Insulation resistance	Min. 100MΩ (at 500VDC megger)			
Dielectric strength	2000VAC 50/60Hz for 1 minute			
Ambient temperature	–10 to 55°C (at non-freezing status)			
Storage temperature	–25 to 65°C (at non-freezing status)			
Ambient humidity	35 to 85%RH			
Approval	CE c UL US			
Unit weight	Approx. 90g			

Multi Function Timer

Connections

AT8N

●[A], [F] mode

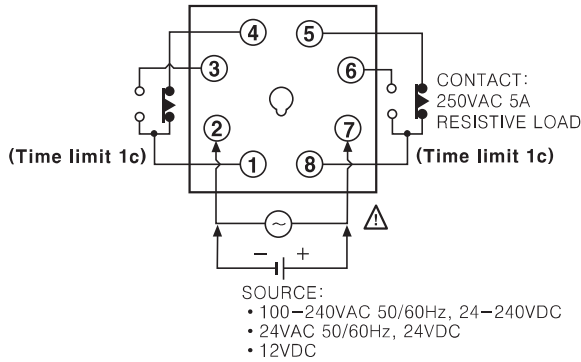

●[A1], [B], [F1], [I] mode

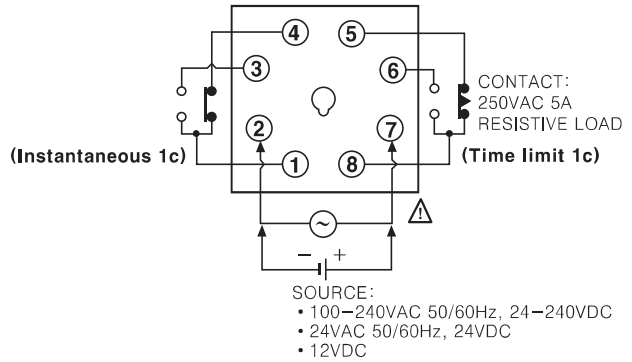

AT11DN

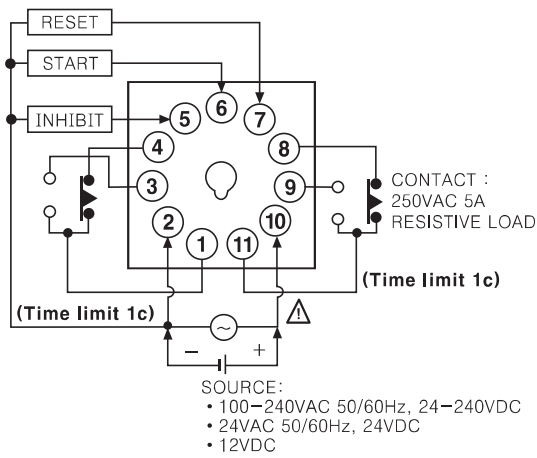

AT11EN

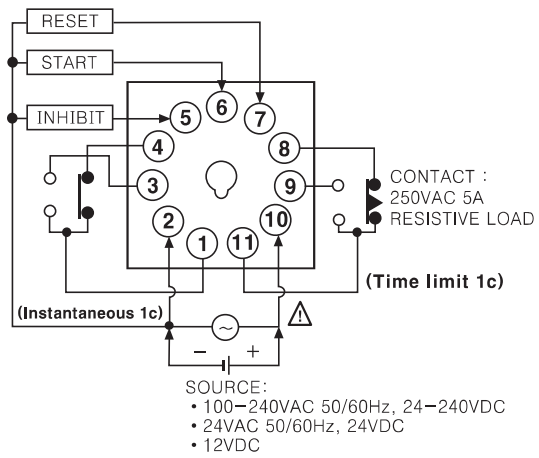

Dimensions

●Bracket

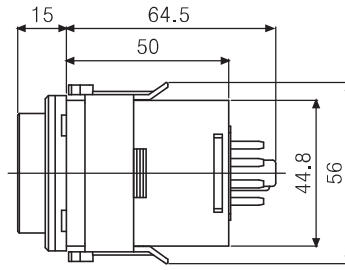
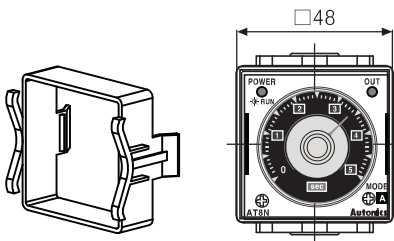

●Panel cut-out

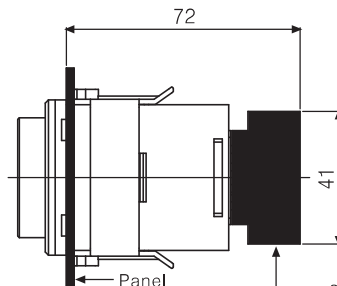
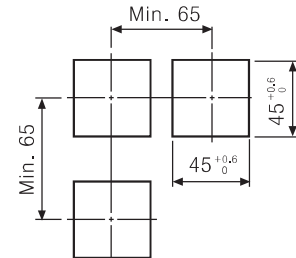

8 Pin socket : PG-08 (Sold separately)
11 Pin socket : PG-11 (Sold separately)
※ Refer to G-11 page.

(A)	Photo electric sensor
(B)	Fiber optic sensor
(C)	Door/Area sensor
(D)	Proximity sensor
(E)	Pressure sensor
(F)	Rotary encoder
(G)	Connector/Socket
(H)	Temp. controller
(I)	SSR/Power controller
(J)	Counter
(K)	Timer
(L)	Panel meter
(M)	Tacho/Speed/Pulse meter
(N)	Display unit
(O)	Sensor controller
(P)	Switching power supply
(Q)	Stepping motor & Driver & Controller
(R)	Graphic/Logic panel
(S)	Field network device
(T)	Production stoppage models & replacement

(Unit:mm)

ATN Series

■ Front panel identification

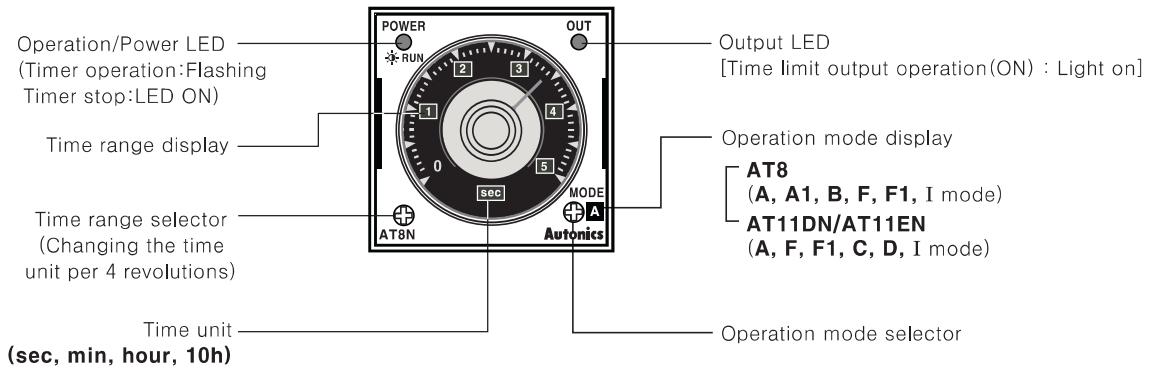

※Please rotate the time range switch and operation mode switch to CW (Clockwise) direction.

■ Time specifications

Time range	Time unit	Time setting range
0.5	sec	0.05 to 0.5 sec.
1.0		0.1 to 1.0 sec.
5		0.5 to 5 sec.
10		1 to 10 sec.
0.5	min	0.05 to 0.5 min.
1.0		0.1 to 1.0 min.
5		0.5 to 5 min.
10		1 to 10 min.
0.5	hour	0.05 to 0.5 hour
1.0		0.1 to 1.0 hour
5		0.5 to 5 hour
10		1 to 10 hour
0.5	10h	0.5 to 5 hour
1.0		1 to 10 hour
5		5 to 50 hour
10		10 to 100 hour

■ Output operation mode of each model

●AT8N

Display	Output operation mode
A	POWER ON DELAY
A1	POWER ON DELAY 1
B	POWER ON DELAY 2
F	FLICKER (OFF START)
F1	FLICKER 1 (ON START)
I	INTERVAL

●AT11DN/AT11EN

Display	Output operation mode
A	SIGNAL ON DELAY
F	FLICKER (OFF START)
F1	FLICKER 1 (ON START)
C	SIGNAL OFF DELAY
D	SIGNAL ON/OFF DELAY
I	INTERVAL

Multi Function Timer

■ AT8N Output operation mode

t:Setting time, $t > t-a$, Rt:Return time, $Rt1 > Rt$

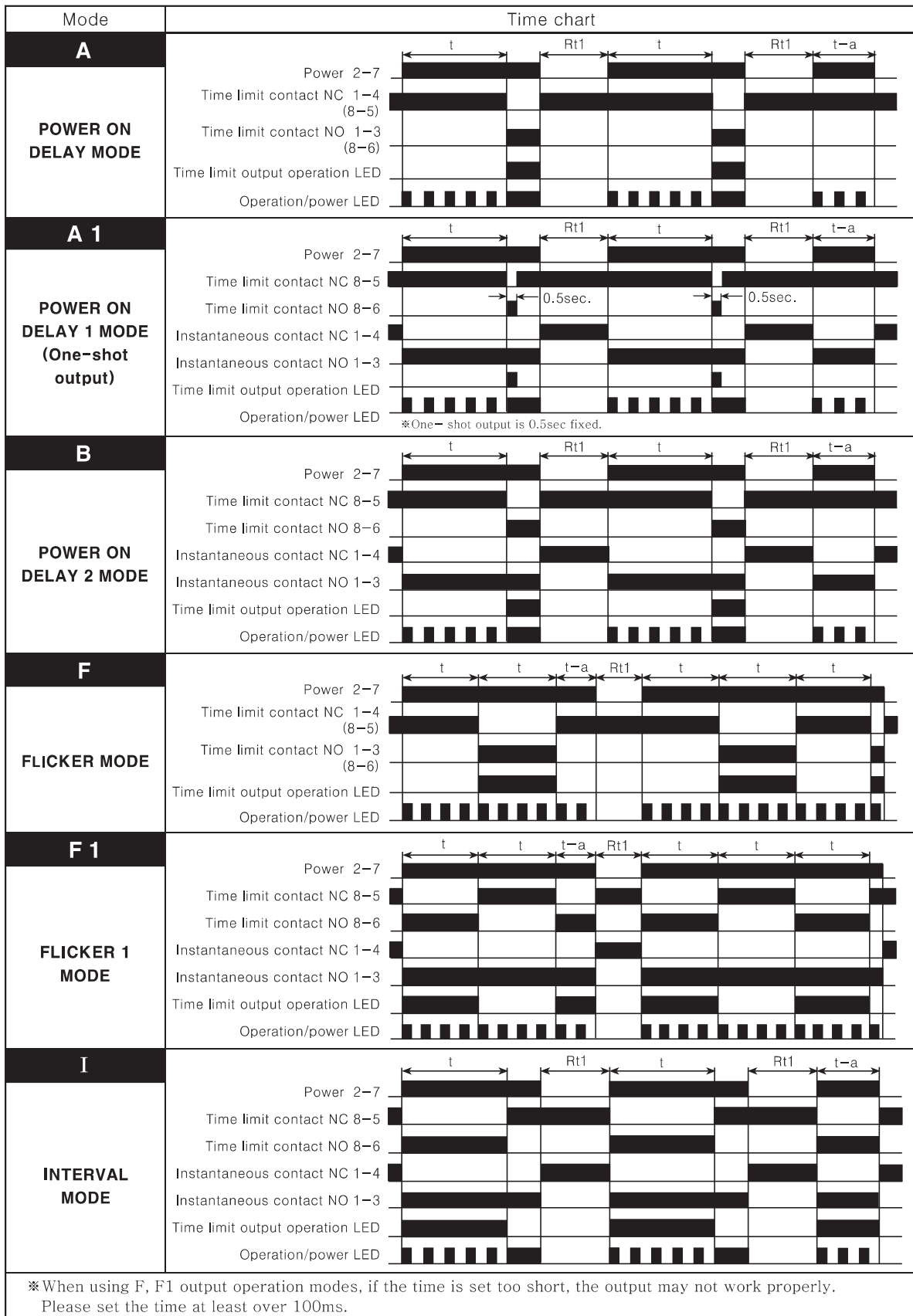

- (A) Photo electric sensor
- (B) Fiber optic sensor
- (C) Door/Area sensor
- (D) Proximity sensor
- (E) Pressure sensor
- (F) Rotary encoder
- (G) Connector/Socket
- (H) Temp. controller
- (I) SSR/Power controller
- (J) Counter
- (K) Timer**
- (L) Panel meter
- (M) Tacho/Speed/Pulse meter
- (N) Display unit
- (O) Sensor controller
- (P) Switching power supply
- (Q) Stepping motor & Driver & Controller
- (R) Graphic/Logic panel
- (S) Field network device
- (T) Production stoppage models & replacement

ATN Series

AT11DN/AT11EN Output operation mode

t:Setting time, $t=t_1+t_2$, $t>t-a$

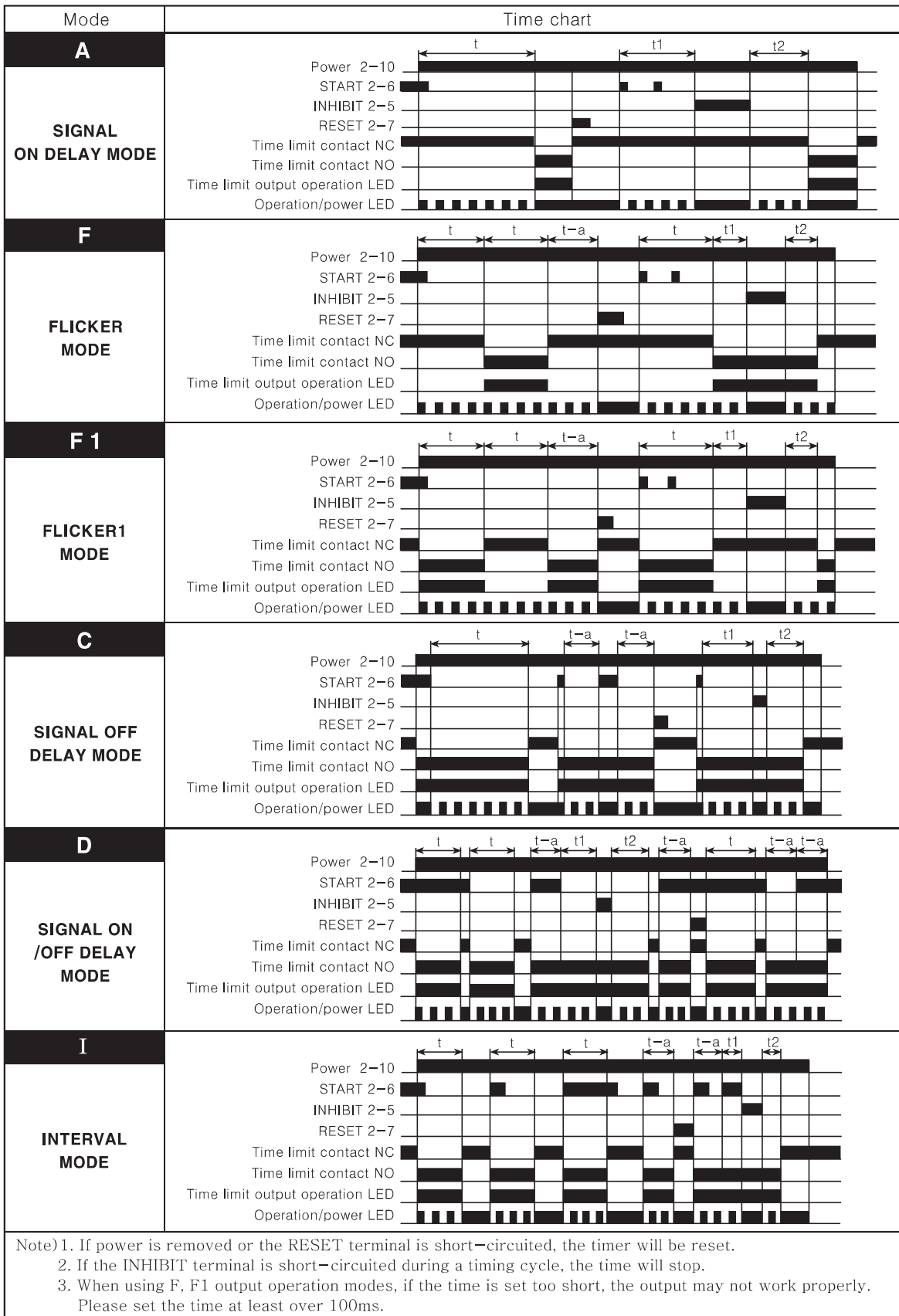

Multi Function Timer

■ Proper usage

◎ Repeat function(Flicker)

- It enables to use one ATN timer for 3 sub relays and 2 timers(Flicker function).
Simple to use flicker function with only one ATN timer.
- Switch A : Start, Switch B : Reset.

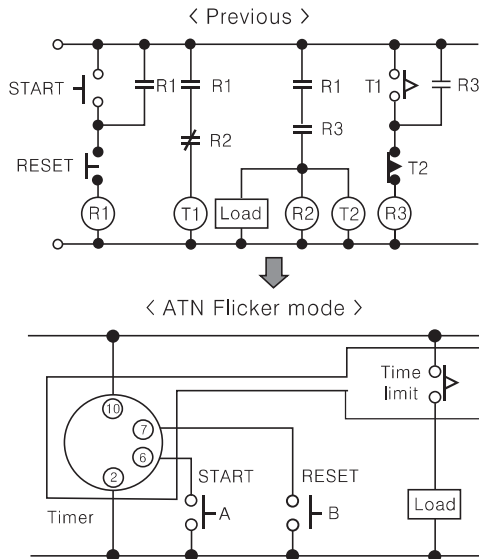

◎ INTERVAL mode

It enables to make instantaneous ON and time limit OFF (Remained circuit) with using INTERVAL mode.

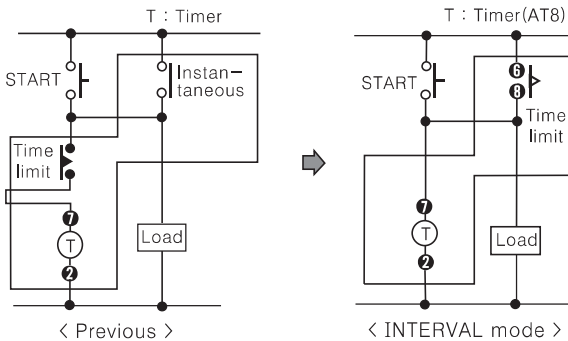

◎ Input signal condition(AT11DN, AT11EN)

1. Relay contact input

Please use gold-plated switches with good contact assurance and short bouncing time for contact input. (Open resistance : Over 100kΩ, Short-circuit resistance : Under 1kΩ)

※ Please use a contact that can function reliably at 5VDC 0.4mA.

2. NPN open collector transistor input

Please use the characteristic of transistor as follow:

V_{ceo} : Min. 25V

I_c : Min. 10mA

I_{cbo} : Max. 0.2μA

Residual voltage : Max. 0.5V

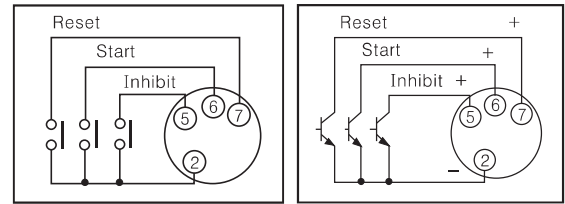

3. NPN universal input

It enables to use voltage output type as input signal source instead of open collector output in solid-state circuit (Proximity sensor, photo-electric sensor) which has range of 10-30VDC output voltage.

When H signal change to L, timer will start.

When transistor(Q) is ON status, please make residual voltage under 0.5V.

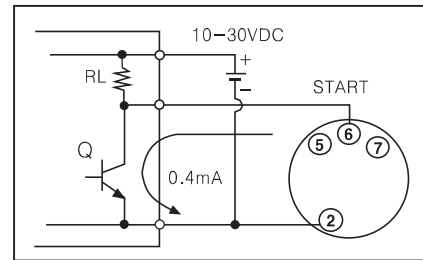

◎ Terminal connection

- 1) Please wire correctly with wiring instructions
- 2) Power connection

Connect the power line without observing polarity for ATN series AC power type, but please be careful of power connection for DC power type.

Power supply	8 Pin type	11 Pin type
AC Type	Terminal ② - ⑦	Terminal ② - ⑩
DC Type	Terminal ② ← ⊖ Terminal ⑦ ← ⊕	Terminal ② ← ⊖ Terminal ⑩ ← ⊕

- When turning off the power, be careful of inductive voltage. (If using power line with another high voltage line or energy line near by, it may cause inductive voltage).

- Power ripple should be under 10% and power supply should be within range of allowable voltage for DC power type.

- Please supply the power quickly when using a switch or a relay contact. Otherwise, it may cause time error or power reset failure.

- 3) The load of Control output should be under rated load capacity.

(A)	Photo electric sensor
(B)	Fiber optic sensor
(C)	Door/Area sensor
(D)	Proximity sensor
(E)	Pressure sensor
(F)	Rotary encoder
(G)	Connector/Socket
(H)	Temp. controller
(I)	SSR/Power controller
(J)	Counter
(K)	Timer
(L)	Panel meter
(M)	Tacho/Speed/Pulse meter
(N)	Display unit
(O)	Sensor controller
(P)	Switching power supply
(Q)	Stepping motor & Driver & Controller
(R)	Graphic/Logic panel
(S)	Field network device
(T)	Production stoppage models & replacement

ATN Series

◎Setting time, time range, operation mode

Do not change time range or operation mode while time operating. When changing it, please power off or apply reset signal.

◎Input connection

1) AT11DN/AT11EN Timer is transformerless type, therefore please check following for connecting relay contact for input signal and transistor.

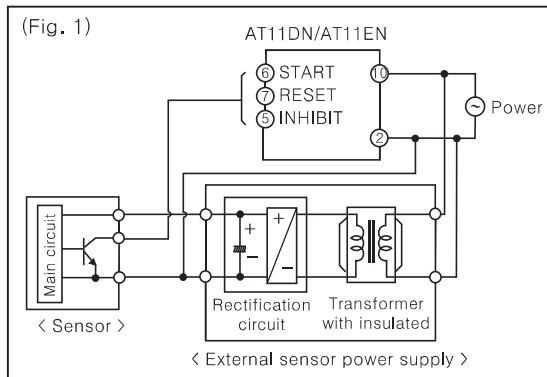

2) When using the terminal ⑩ as a common terminal of input signal as (Fig. 2), it may cause damage to the inner circuit of AT11DN/AT11EN, please use the terminal ② for common terminal as (Fig. 3).

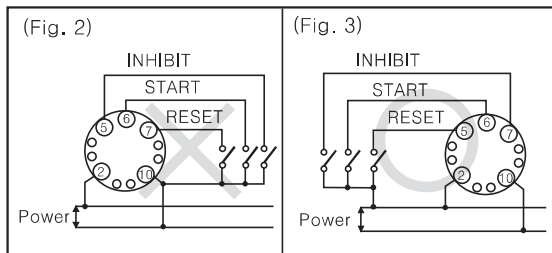

3) When using more than one timer with one contact or transistor input, the short current is flowed when it is connected as (Fig. 4). Please connect the power phase correctly as (Fig. 5) correctly.

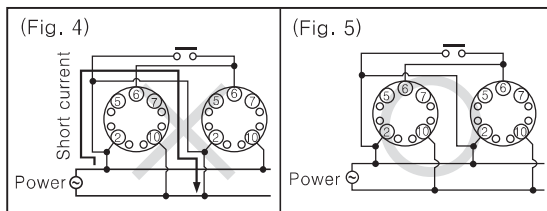

4) INHIBIT, START, RESEST signal applied by short-circuiting input terminal ②-⑤, ②-⑥ or ②-⑦.

It may cause internal circuit damaged by wrong connection.

5) If using power line with another high voltage line or energy line at the same conduit, it may cause inductive voltage. Therefore please use seperated conduit for power line.

6) When input (INHIBIT, START, RESEST) wire is long, please use shield wire and it should be short.

◎Common

- 1) For DC power supply type, be sure to check the polarity of terminals.
- 2) In case of 12VDC, 24VAC/DC model, isolated and limited voltage/current or Class 2 source should be provided for power supply.
- 3) When supply the power to the timer, connection shown in (Fig. 6) might cause malfunction due to leakage current through R and C. Please connect R and C as shown in (Fig. 7) to prevent malfunction.

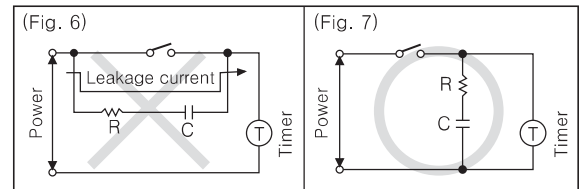

4) It might cause malfunction if changing the setting time, time range or operation mode during operating unit. Please change the the setting time, time range or operation mode after cut the power off.

5) Do not use this unit at below places.

- Place where there are severe vibration or impact.
- Place where strong alkalis or acids are used.
- Place where there are direct rays of the sun
- Place where strong magnetic field or electric noise are generated.

6) Installation environment

- It shall be used indoor
- Altitude Max. 2000m
- Pollution Degree 2
- Installation Category II.