

Operating Instructions EK / EKK 43

„Powerful Combination“

EK 43
EKK 43



The professional art of grinding
since 1924

Coffee Laboratory 589 Rappahannock Drive White Stone Va 22578 TEL (866) 244-1578 www.coffeelabequipment.com

Dear Customer,

with the “EK 43” or “EKK 43” you have purchased a grinder in the well-known MAHLKÖNIG quality.

Our over 80 years of experience in the production and development of grinders have helped us to develop a new product in the MAHLKÖNIG company.

As usual, this product guarantees top-quality by grinding of all types of coffee, spices and grains.

Before putting the device into service, please read these operating instructions including the safety instructions carefully and observe them at all times. Also instruct your personnel accordingly.

Enclosed you will find many useful tips that will make it easier for you to use the grinder. Keep these operating instructions in a safe, easily accessible location. In case of any unclear points or additionally required information, please contact your local dealer or us directly as the manufacturer.

MAHLKÖNIG GmbH & Co. KG

Table of Contents

1. Safety	4	7. Operating Faults	9
1.1 Symbols	4	8. Grind Adjustment Calibration	11
1.2 Safety Instructions	4	9. Cleaning the Grinder	11
1.3 Purpose of Use	5	9.1 Cleaning with GRINDZ™ Grinder Cleaner	12
1.4 User Requirements	5	9.2 Cleaning the Grinder Casing	12
2. Technical Data	5	9.3 Cleaning the Grinding Mechanism	12
3. Description	6	10. Maintenance and Repair	13
4. Safety Devices	7	10.1 Grinding Disc Replacement	13
5. Setting Up and Basic Adjustment	7	11. Spare Parts	14
5.1 Setting-up area	7	12. Wiring Diagrams	14
5.2 Installation	7	13. Certificates	16
6. Operation	8	14. Warranty Conditions	17
6.1 How to use the grinder	8		
6.2 What can be ground?	9		

1. Safety



Please read and observe the following operating instructions carefully. Non-observance can result in damage to the device as well as in health-threatening risks for the user.

1.1 Symbols

The following two symbols are used in this manual of operating instructions:



Safety instruction:

In case of non-observance, extreme risk of accidents exists.



General instruction:

In case of non-observance, the device can become damaged or optimum operation not be guaranteed.

1.2 Safety Instructions

Never use the grinding mechanism to grind other products or objects. Ground material is never allowed to be filled into the hopper.

Do not carry out any modifications or changes on the grinder. In case of non-observance, the manufacturer shall be liable for resulting damage in no case whatsoever.

Never operate the grinder in moist or, even worse, in wet surroundings.

Never put your fingers or objects into the rotating grinding mechanism underneath the hopper.

Always pull the power supply plug out of the outlet before carrying out any maintenance or cleaning work on the device.

Never put the device into service with a defective power supply cable. Check the device regularly for any signs of damage on the power supply cable, plug, finger protector, etc.

Any repairs that may be required are only allowed to be carried out by experts. Please contact an authorised customer service centre, your local dealer or us directly as the manufacturer.

Do not exceed the permissible maximum operating period of 40 minutes. Afterwards, allow the motor to cool down for approx. 30–40 minutes.

When unpacking the device, please check to determine whether the power supply voltage (volts) corresponds to the device voltage on the rating plate.

Children do not recognise the risks that may arise when handling electrical devices; therefore never leave children alone with electrical devices without proper supervision.



Never immerse the device in water and do not operate it with wet hands.

1.3 Purpose of Use

You can only use the grinder you have purchased to grind the goods for which the grinder has been designed. Please make sure that only clean and whole coffee beans are ground. Never use the grinder to grind any other products or objects.

Example:

You can use the EGM 43 combination grinder (with different grinders) to grind grain on one side and poppy seeds on the other.



1.4 User requirements

No special requirements are specified for the users of this device. It is, however, assumed that this manual of operating instructions has been carefully read and understood and that all instructions provided in this manual will be observed. In addition, working with the device on a safety-conscious basis is also expected.

2. Technical Data

Description	EK43, EL43, EM43, EG43, EP43, EKK43, EGL43, EGM43, EKM43, EML43, EPP43
Voltage/Frequency	230V / 50Hz 115V / 60Hz
RPM	
@ 50 Hz	1480 rpm.
@ 60 Hz	1740 rpm.
Sound emission	
Idle operation	60 dB
Operation	87 dB
Pre-fuse	16 A-slow
Overload circuit breaker	
230V	7A T
115V	12A T
Permissible max. operating time of the grinder	40 minutes
Dimensions in mm	
EK 43	B 230, T 410, H 770
EKK 43	B 230, T 590, H 770
Net-weight	
EK 43	24 kg
EKK 43	28 kg
Hopper capacity	
EK 43	1500 g
EKK 43	2 x 1500 g

(Please ask the manufacturer or dealer for technical data on other voltages and frequencies.)

3. Description

The main components and operating elements are shown in the figure.

- Pos. 1 Hopper
- Pos. 2 Adapter with hopper slider
- Pos. 3 Grind adjustment
- Pos. 4 Bag holder
- Pos. 5 Bag holder handle
- Pos. 6 Reset button
- Pos. 7 ON switch "I", green
- Pos. 8 OFF switch "0", red
- Pos. 9 Base
- Pos. 10 Residue tray



4. Safety Devices

Thermal overload circuit breaker

The motor of the grinder is protected by an overload circuit breaker, which interrupts the electric circuit of the motor when the device is subjected to electric overloading. To be able to re-start the grinder, the reset button on the side of the casing must be pressed.



The user has no influence whatsoever on this operation. In case of repeated tripping of the circuit breaker, an expert must be consulted since this could cause damage to the motor winding.

Motor protector (winding shield)

The grinder is protected against thermal overloading by a motor protector (thermostat, inserted in the winding). Whenever the winding of the motor heats up to an impermissible level, the motor protector interrupts the electric circuit of the motor.

Following a cool-off phase (approx. 1 hr.), the motor protector is switched on again automatically and the grinder can be re-started.

5. Setting-up and Basic Adjustment

A grinding test run is carried out on each grinder in the manufacturer's factory. This is why you may find ground material residue in the grinding mechanism!

5.1 Setting-up Area

Place the grinder on a level surface free from vibration.



Never operate the grinder in moist, or even worse, in wet surroundings.

5.2 Installation

You have received your grinder in operating condition. Now you only need to connect it to a power supply system. Proceed as follows:



Protect your device with a separate pre-fuse (not included in the scope of supplies) according to the information provided in „Technical data“ under 2.



Make sure that the pre-fuse is not overloaded by other consuming devices (e.g. fan-forced heaters, deep freezers).



Determine whether the mains voltage and frequency correspond to the information on the rating plate.

Insert the plug into the available grounded outlet.

6. Operation

6.1 How to use the grinder

1. By moving the rotary knob (pos.3), set the required grind degree (to the left for coarse grind, to the right for finer grind).
2. Only fill whole coffee beans (unground material) into the hopper (pos.1). Close the hopper.
3. Press the handle of the bag holder down (pos.5) and push the completely opened bag, which has been smoothed along the folds, over the spout. Let go of the handle and the bag is held firmly in position.
4. Now you can switch on the grinder (pos.7).



Knock the base of the bag a number of times whilst grinding. This allows the maximum capacity of the bag to be used.



In the case of the combination grinder, by turning the combined On / Off - selection switch you can select the grinder you wish to use. You can only grind on the side of the grinder casing side you have selected. You cannot grind on both sides at the same time.

5. Once all material has been ground, hold the bottom of the bag gently in one hand. Use the other hand to press the handle of the bag holder and allow it to knock against the spout 2 – 3 times. This removes any ground particles which may still be attached to the inside of the spout
6. Now switch off the grinder (pos. 8)



7. Remove the filled bag from the spout. The grinding process is terminated. Close the main hopper slider.

6.2 What can be ground?

Grinder	products which can be ground
EK 43	Coffee
EL 43	Linseed
EM 43	Poppy seed
EG 43	Grain
EP 43	Spices
EKK 43	Coffee / Coffee
EGL 43	Grain / Linseed
EGM 43	Grain / Poppy seed
EKM 43	Coffee / Poppy seed
EML 43	Poppy seed / Linseed
EPP 43	Spices / Spices

7. Operating faults

Defect	Cause	Remedy
The grinder hums but does not grind.	The spout is clogged.	Set grinding fineness to „coarse“ and trigger the grinding process. The grinder will then grind itself free. Afterwards, return the setting to the desired grinding fineness.
	Grinding is set too fine.	Turn the grinding fineness setting to the right, to „coarse“, and trigger the grinding process. The grinder will then grind itself free. Afterwards, return the setting to the desired grinding fineness.
	A foreign object is in the grinding mechanism.	Clean the grinding mechanism as described and remove the foreign object. Observe the safety instructions!

Defect	Cause	Remedy
The grinder does not start.	The power supply plug is not inserted.	Insert the plug into the outlet.
	The overload circuit breaker has been tripped.	Check to determine whether the reset button of the circuit breaker has jumped out. Press the reset button in again if appropriate. In case of repeated tripping of the circuit breaker, contact your authorised customer service centre or dealer.
	The motor protector was tripped.	Give the grinder a cooling-off break of approx. 1 hr.
	The pre-fuse was tripped.	Check the pre-fuse. Restore the pre-fuse to its initial state or replace it. Determine whether other consuming devices are also connected to this fuse.

Defect	Cause	Remedy
Grinder rotates but without grinding..	Carrier breakage.	Remove the grinder casing cover, take out the broken pieces of the driver, insert a new driver and then install the grinder casing cover again.
	Incorrect sense of rotation.	Have the polarity checked by specialised personnel.
Scratching noise after switch-off in idle run.	The centrifugal switch closes at a slower rotation and reconnects the starting capacitor.	No remedy needed. Standard operation.
Loud buzzing noise after switch-on in idle operation.	Vibrations inside between rotating parts.	Switch off and on the grinder. Exchange the shear plate and grease the rotating parts to minimise vibrations.

In case of other malfunctions or continued faults, please contact your dealer or your authorised customer service centre.

8. Grind Adjustment Calibration

The grinder has been precisely adjusted by the manufacturer. However, if the ground material is no longer fine enough after a longer period, the grinder must then be re-adjusted according to the following procedure:

1. Turn the rotary knob to position 1 "fine". Loosen the two threaded pins by approx. 1 rotation using the 3 mm hexagon spanner enclosed in delivery. The two threaded pins are positioned in the drilled holes of the rotary knob.
2. Now switch on the grinder.
3. Using a screwdriver or coin, carefully turn the large adjustment screw with the slot to the right until you hear a rattling noise (grinding disc are touching). Turn the adjustment screw back by approx. 10 degrees and the rattling sound should stop.
4. If you grind some beans now, you should get fine grains (in the case of coffee). If the coffee beans have been ground too fine, the discs can stick together. The grinder would be blocked.



It is important that the rattling sound cannot be heard in the finest grinding position. Otherwise the service life of the grinding discs is reduced considerably!

5. If the adjustment you have made does not come up to your expectations you can adjust the grind degree as described above.

9. Cleaning the Grinder



Always pull the power supply plug out of the outlet before carrying out any maintenance or cleaning work on the device!



Observe the safety instructions under 1.2!



Do not let any foreign objects fall into the grinding mechanism!!

9.1 Cleaning with GRINDZ™ Grinder Cleaner

We recommend cleaning your shop grinder once a month with our GRINDZ™ Grinder Cleaner.

Simply take the recommended dose of 70 - 80g for shop grinders and drop it into the empty grinder hopper. You can also use the cap of the jar for dosing. A full cap will yield between 35 - 40 grams.

Adjust the machine setting to medium and operate like standard grinding procedure. Once complete, we recommend passing twice as much original material through to purge any residue.

9.2 Cleaning the grinder casing

Clean the casing of your grinder every now and then with commercially available mild cleaning agents. In addition, you should also clean the hopper from time to time.



Do not let any foreign objects fall into the grinding mechanism!!

9.3 Cleaning the grinding mechanism



Pull out the power supply plug !

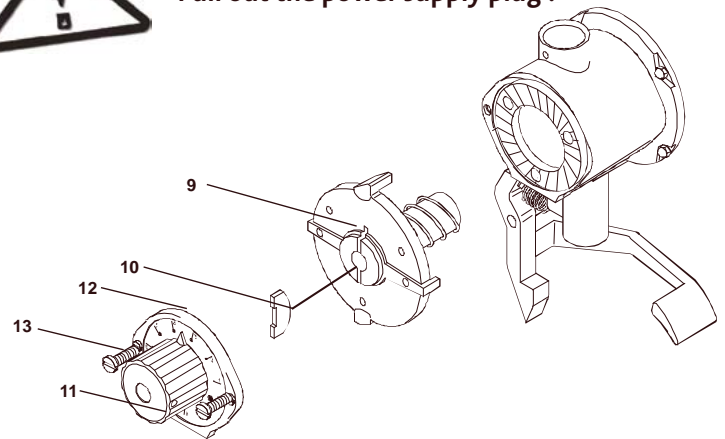

1. Rotate the rotary knob (11) to „coarse“.
2. Unscrew the two screws (13) on the grinder casing cover (12) and then remove this cover.
3. Take the carrier (10) out of the slot of the pre-breaker.
4. Pull the pre-breaker (9) off the motor shaft. Use a screw driver.

5. Clean the grinding mechanism with a fine brush and remove any foreign objects.
6. Before pushing the pre-breaker (9) back onto the shaft again, lubricate the shaft with non-corrosive, resin-free and food-stuff-compatible grease (e.g. Vaseline).
7. After you have pushed the pre-breaker onto the shaft, line up the two slots so that you can then easily re-insert carrier (10).



The rounded side of the driver must point towards the motor.

8. Clean the contact surfaces of the grinder casing and grinder casing cover (12) carefully in order to remove any form of soiling.



During re-assembly, no ground material should stick to the surfaces where the grinder casing and the cover touch.

9. Screw down the cover (12) tightly with the two screws (13) while changing the side several times.
11. Rotate the rotary knob to the desired grind degree. The grinder is now ready for operation again.

Poppy seed grinders shall be cleaned once a week!

Coffee Laboratory 589 Rappahannock Drive White Stone Va 22578 TEL (866) 244-1578 www.coffeelabequipment.com

10. Maintenance and Repair



Always pull the power supply plug out of the outlet before carrying out any maintenance or cleaning work on the device!



Check the device regularly for any signs of damage on the power supply cable, plug, finger protector, etc.



Any repairs that may be required are only allowed to be carried out by authorised experts. Please contact an authorised customer service centre or your local dealer.

10.1 Grinding Disc Replacement

If the grinding performance decreases and the ground products are hot and irregular, you should change the grinding discs.

1. Take the grinder apart as described under “9” and remove the grinding discs from the grinder casing and the pre-breaker using a screwdriver.
2. Clean the surfaces of the new grinding discs thoroughly and screw them in position tightly and evenly.
3. Close the grinder casing again as described under “9” and set the grind degree again as described under “8”.

11. Spare Parts

Spare parts are usually ordered from your customer service centre or your local dealer. To ensure quick, correct processing of your order, the following information is absolutely required:

1. Type designation and serial number of the grinder (on the rating plate on the rear side of the grinder).
2. Color of the grinder

12. Wiring Diagram EK 43 115V 60Hz

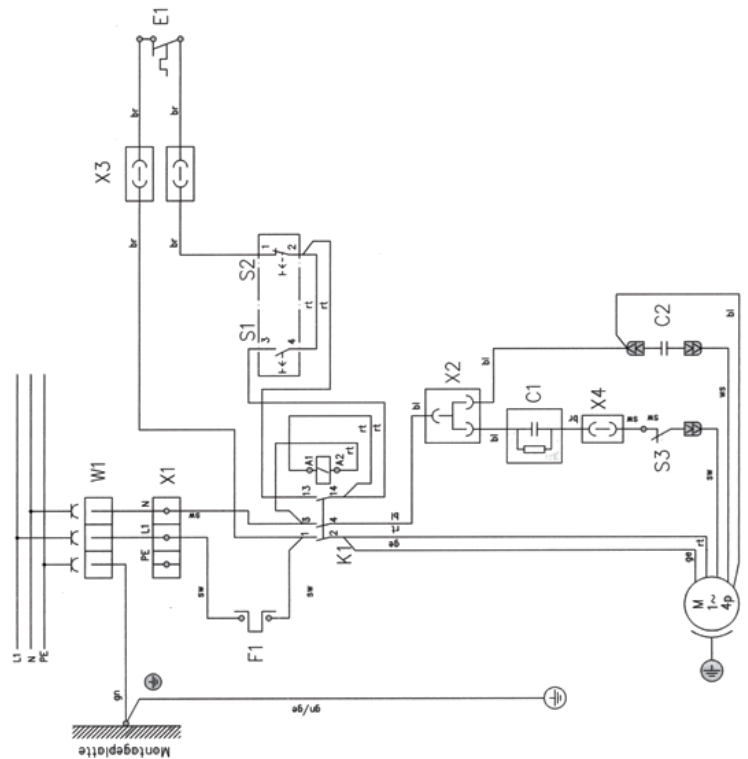

Wiring Diagram EK 43 230V 50Hz

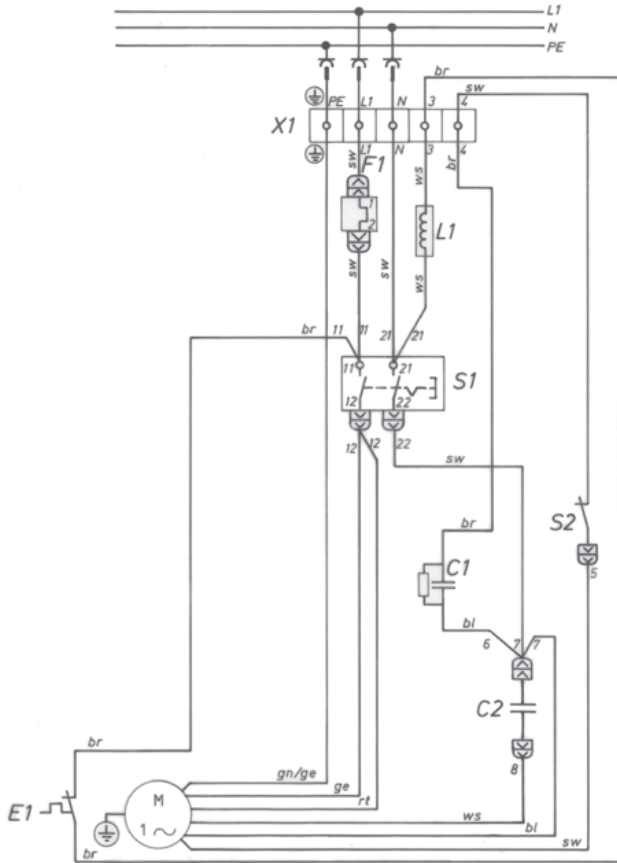

Wiring Diagram EKK 43 115V 60Hz

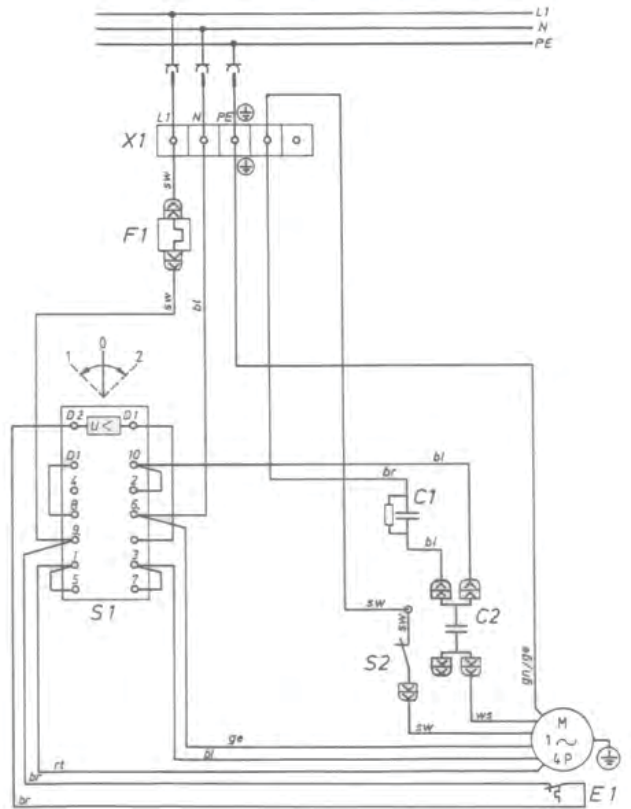

Coffee Laboratory 589 Rappahannock Drive White Stone Va 22578 TEL (866) 244-1578 www.coffeelabequipment.com

Wiring Diagram EKK 43 230V 50Hz

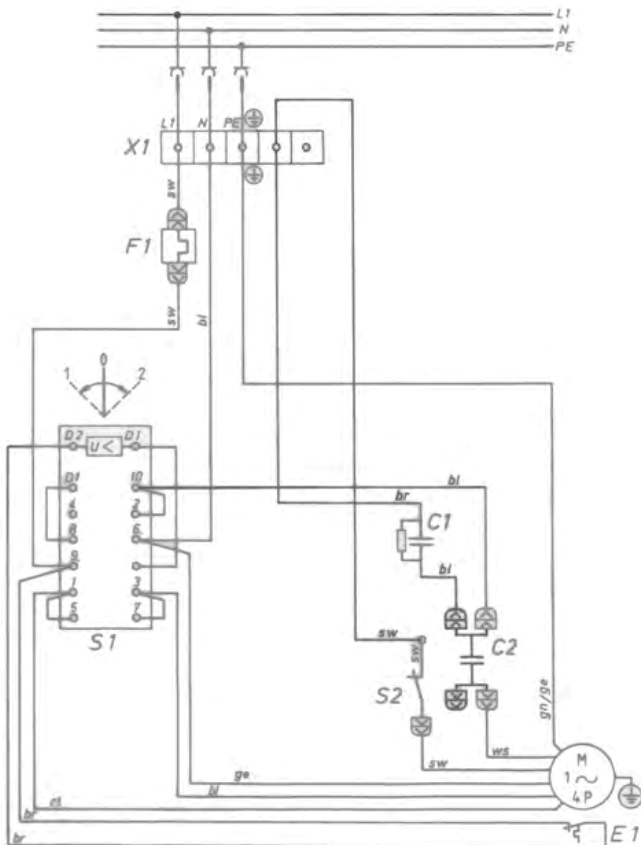

13. Certificate

EC Declaration of Conformity



The manufacturer: MAHLKÖNIG GmbH & Co. KG
 Tilsiter Straße 142
 D - 22047 Hamburg
 Tel: +49 (0) 40 69 69 40 - 0
 Fax: +49 (0) 40 69 39 72 - 1

hereby declares that the below mentioned product:

product type: device for food processing
machine description: Coffee grinder
machine typ: EKK43 / EGL43 / EGM43 / EKM43 / EPP43 / EML43

is in compliance with the following directives and regulations:

- The provisions of the Machinery Directive 2006/42/EG
- The Low Voltage Directive 73/23/EWG
- The EC Electromagnetic Compatibility Directive 2004/108/EG
- The Directive on the restriction of use of certain hazardous substances in electrical and electronic equipment 2011/65/EU
- The EU chemicals regulation (REACH - Regulation) (EG) Nr. 1907/2006

Supplements in Europe:

Regulation 1935/2004 Requirements for materials and the objects with Food comes into contact

Documentation Agent: Sven Erdmann

Address of the proxy documentation: See the address of the manufacturer

Done in Hamburg on: 01.08.2013

Function of subscriber: General Manager

Name of signatory: Philipp Baumberger

Signature

MAHLKÖNIG GmbH & Co. KG, Amtsgericht Hamburg HR A 85 074, Persönlich haftende Gesellschafterin:
 Beteiligungsgesellschaft MAHLKÖNIG mbH, Eingetragenes Amtsgericht Hamburg HR B 45 344,
 Geschäftsführer: Nils Erichsen, Philipp Baumberger, Jochen Christoph
 Dresdner Bank AG (B.I.Z. 2000 8000 00) Kto. 383 780 420, Postbank Hamburg (B.I.Z. 2000 100 20) Kto. 253 89 203.

EC Declaration of Conformity



The manufacturer: MAHLKÖNIG GmbH & Co. KG
 Tilsiter Straße 142
 D - 22047 Hamburg
 Tel.: +49 (0) 40 69 69 40 - 0
 Fax: +49 (0) 40 69 39 72 - 1

hereby declares that the below mentioned product:

product type: device for food processing
machine description: Coffee grinder
machine typ: EK43 / EL43 / EM43 / EG43 / EP43

is in compliance with the following directives and regulations:

- The provisions of the Machinery Directive 2006/42/EG
- The Low Voltage Directive 73/23/EWG
- The EC Electromagnetic Compatibility Directive 2004/108/EG
- The Directive on the restriction of use of certain hazardous substances in electrical and electronic equipment 2011/65/EU
- The EU chemicals regulation (REACH – Regulation) (EG) Nr. 1907/2006

Supplements in Europe:

Regulation 1935/2004 Requirements for materials and the objects with Food comes into contact

Documentation Agent: Sven Erdmann

Address of the proxy documentation: See the address of the manufacturer

Done in Hamburg on: 01.08.2013

Function of subscriber: General Manager

Name of signatory: Philipp Baumberger

Signature

MAHLKÖNIG GmbH & Co. KG, Amtsgericht Hamburg HR A 85 074; Persönlich haftende Gesellschafterin:
 Beteiligungsgesellschaft MAHLKÖNIG mbH, Eingetragenes Amtsgericht Hamburg HR B 45 324,
 Geschäftsführer: Nils Erichsen, Philipp Baumberger, Kochen Christoph
 Dresdner Bank AG (BIZ 200 800 00) Kto. 383 780 400; Postbank Hamburg (BIZ 200 100 20) Kto. 253 89 203

14. Warranty Conditions

1. The warranty period is 1 year from the date of purchase.
2. The warranty covers all damages that can be attributed to inferior materials or defective workmanship. Corresponding grinders will be repaired or replaced free-of-charge, with the exception of transport or freight charges. Transport is the responsibility of the customer. Therefore, avoid damages with all returns by correct packing.
3. The grinder may only be opened for cleaning purposes in accordance with the Operating Instructions.
4. This warranty does not cover damages which have occurred through: Improper usage, improper maintenance, lack of servicing, usage for purposes other than those intended, incorrect installation, incorrect voltage, breakage, natural wear or for reasons beyond our sphere of influence.
5. In order to maintain the warranty, only original spare parts and accessory parts may be used.
6. Observe in addition our General Delivery Conditions in their respective current version.
7. The manufacturer is in no way liable for consecutive or secondary damages.
8. The warranty does not cover costs emerging from repairs conducted by non-authorized personnel.

Notes:

Notes:

MAHLKÖNIG GmbH & Co. KG

Tilsiter Straße 142
D- 22047 Hamburg, Germany

Tel.: +49 (0)40 / 69 69 40-0

Fax: +49 (0)40 / 69 39 721

office@mahlkoenig.de ; www.mahlkoenig.de

March 2015

Subject to change without prior notice!!



The professional art of grinding
since 1924

Coffee Laboratory 589 Rappahannock Drive White Stone Va 22578 TEL (866) 244-1578 www.coffeelabequipment.com