



**SINAR**  
TECHNOLOGY

## The Sinar Technology DryPro

'In dryer moisture monitoring and control - preventing the problems of over & under drying in a large variety of crops.'

The **Sinar DryPro** heralds a breakthrough in crop moisture control, providing real time moisture content & temperature readings, which allows fine-tuning of the dryer to **maximize throughput** and **minimize fuel wastage**.

Manual sampling of the crop as it exits the dryer is time consuming, and relies on small samples to represent the moisture content of the grain remaining in the dryer. Also, you are always looking back at what has already happened inside your drier, making fine control of the drier a matter of trial and error.

The Sinar DryPro, based on proven capacitance technology, continually reads the moisture of the grain as it passes the sensors positioned throughout the dryer. This gives you real-time moisture and temperature readings as the grain is still in the drier, allowing much tighter control of your drying operation.

By taking hundreds of readings per hour the Sinar DryPro gives you the data to make the correct drier management decisions. Alternatively, using the optional analogue outputs, let the Sinar DryPro make the adjustments for you.

Easily installed into existing dryers, the Sinar DryPro can be configured to trigger high and/or low moisture alarms, continually log moisture and temperature results and provide a variety of outputs which can be used to **monitor or directly control the drier**.

The Sinar DryPro also uses the same standard calibrations developed for use in the Sinar Technology's range of hand held moisture analyzers. This gives the system great flexibility as it can be calibrated for any of the hundreds of commodities listed in our calibration library, as well as allowing easy checking and adjustment.

Typically, these include (many more available):

- Wheat
- Barley
- Oilseed Rape
- Maize
- Soya Bean
- Rice
- Coffee
- Pulses
- Linseed
- Oats

## Technical Description

The **Sinar DryPro** is a unique, multi-sensor, moisture & temperature-monitoring system, designed specifically to cope with the harsh environment found inside modern grain drying facilities.

Up to four sensors can be connected to the central control unit enabling precise measurements to be taken at different points within the dryer. These sensors are easily mounted, with no re-engineering of the dryer required. One 4-core cable is run from each sensor back to the control unit, which is powered from an AC supply. Each sensor can be situated up to 100m away from the control unit.

From the control unit the operator can:

- Continually display the moisture reading from any sensor
- Continually display the temperature reading from any sensor
- Sequentially cycle through, and display, the moisture readings from all available sensors, using a variable time.

Using either an RS232 or RS485 port, the control box outputs:

- Moisture reading displayed on the readout
- Sensor number which is generating the reading
- Current date - in dd/mm/yy format
- Current time – in hr/min/sec format
- Temperature of each sensor
- Name of the crop calibration currently selected
- Current alarm state for selected crop

A data logger, a PC running **Sinar Technology MLog** software or a serial printer/chart recorder, can be used to pick up all this data. In this way a permanent drying record can be easily kept.

The control box also incorporates up to eight analogue outputs, one each for the moisture content reading output from each installed sensor, and one each for the temperature reading on each installed sensor.

This allows the Sinar Drypro to interface with:

- A PLC for control purposes. This enables the dryer to be controlled directly from the readings of the DryPro sensors.
- A chart recorder.

## Schematic of typical Sinar DryPro Installation



STANDARD  
SENSOR



FLAT SENSOR

**Please note:**  
As the system is so flexible, the sensors can be positioned anywhere. This diagram shows one suggested arrangement.

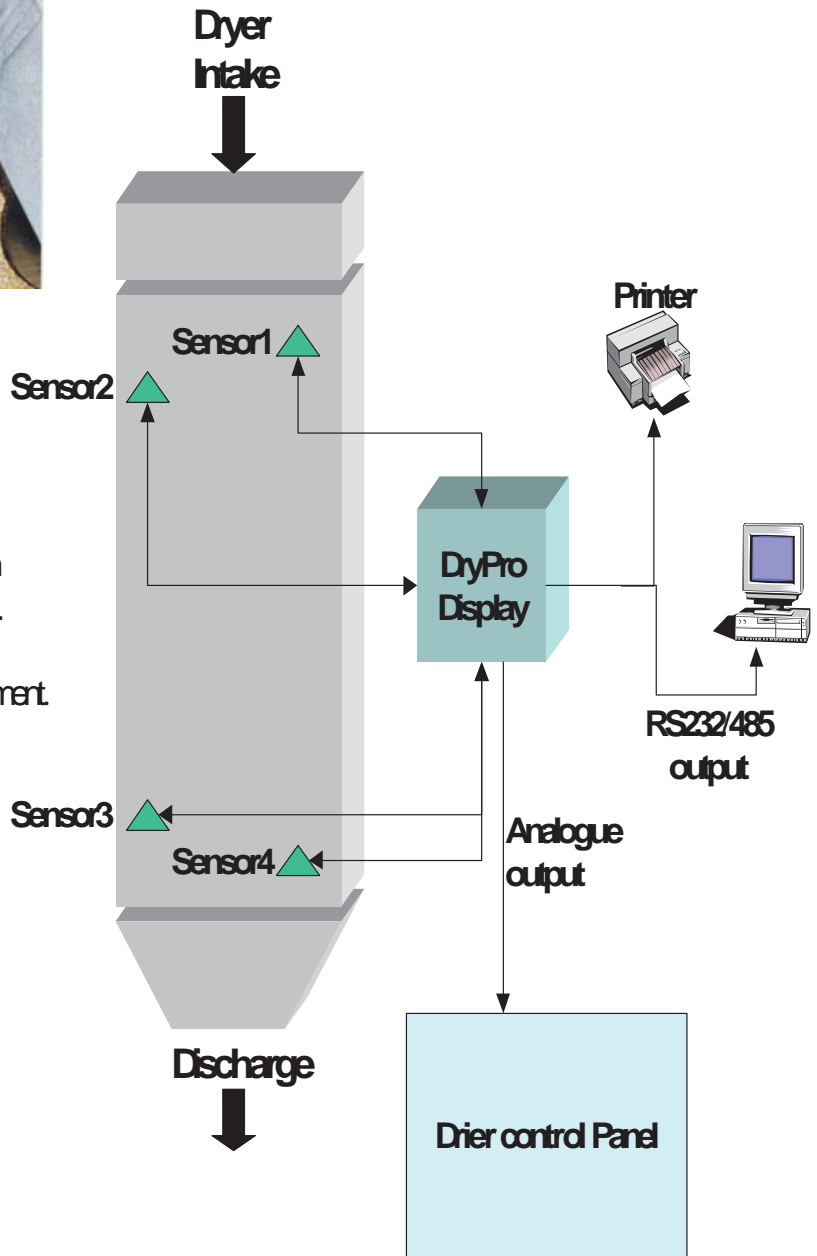

# Technical Specifications

## DryPro Display Unit

<b>Dimensions (mm)</b>	H300 x W400 x D150
<b>Weight</b>	8Kg
<b>Max. no. Sensors</b>	4
<b>Max. Distance To Sensor</b>	100m
<b>Construction</b>	Mild Steel Powder Coated
<b>Control box mounting</b>	4 wall mounting lugs
<b>Operating environment</b>	0°C to +55°C
<b>Storage Temp.</b>	0°C to +55°C
<b>Operating humidity</b>	Up to 95% non-condensing
<b>Display</b>	Alphanumeric LCD, 2 x 20 Characters
<b>Processor</b>	Intel 80C31 microprocessor
<b>Memory</b>	EPROM & RAM
<b>Calibrations Supplied</b>	7 upgradable via RS232 port
<b>Max. Calibration capacity</b>	25 calibrations
<b>Data Output Format</b>	RS232 C, ASCII code, 300 Baud or RS485
<b>Moisture Accuracy</b>	Typically 0.5% dependant on moisture range
<b>Temperature Accuracy</b>	Typically 1°C
<b>Displayed Temperature</b>	°C or °F
<b>Readout Interval</b>	Variable
<b>Display Resolution</b>	1 Decimal Place
<b>Optional analogue output</b>	4-20mA 4 temp opto. isolated outputs 4 moisture opto isolated outputs
<b>Power Supply</b>	
<b>#1 UK &amp; Australia</b>	240V 50Hz 0.36A
<b>#2 Continental Europe</b>	220V 50Hz 0.36A
<b>#3 USA &amp; Canada</b>	120V 60Hz 0.7A
<b>Fuse (FS1) size &amp; Rating</b>	250V 20mm 315mA(F) Quick blow
<b>Temperature Correction</b>	Software correction within range 0-40°C

## DryPro Sensor

<b>Dimensions (mm)</b>	Ø80 x 380
<b>Weight incl. Mtg. Bkt.</b>	1.2Kg
<b>Cable length supplied</b>	2m
<b>Storage Temperature</b>	0°C to +70°C
<b>Operating Temperature</b>	0°C to +70°C
<b>Operating humidity</b>	Humidity up to 95% non-condensing